



Mr. SLIM

# Air-Conditioners

## SUZ-M·VAD-A Series

---

### INSTALLATION MANUAL

For safe and correct use, read this manual and the indoor unit installation manual thoroughly before installing the air-conditioner unit.

FOR INSTALLER

English

# Contents

|   |   |                                 |    |
|---|---|---------------------------------|----|
| 1. The following should always be observed for safety ..... | 1 | 5. Refrigerant piping work..... | 6  |
| 2. Selecting the installation location .....                | 2 | 6. Electrical work .....        | 9  |
| 3. Installation diagram .....                               | 5 | 7. Maintenance.....             | 13 |
| 4. Drain piping for outdoor unit (Fig. 4-1).....            | 6 | 8. Pumping down.....            | 13 |

## Required Tools for Installation

|                           |                               |   |
|---------------------------|-------------------------------|---|
| Phillips screwdriver      | 4 mm hexagonal wrench         | Appropriate personal protective equipment<br>The installer should ensure they check the respective Work Health and Safety (WHS) Act within their jurisdiction as the requirements and obligations may differ. |
| Level                     | Flare tool for R32, R410A     |   |
| Scale                     | Gauge manifold for R32, R410A |   |
| Utility knife or scissors | Vacuum pump for R32, R410A    |   |
| 65 mm hole saw            | Charge hose for R32, R410A    |   |
| Torque wrench             | Pipe cutter with reamer       |   |
| Wrench (or spanner)       |                               |   |

- ⚠ Caution:**
- Do not vent R32 into the atmosphere.
  - Confirm that the installation satisfies “the requirements in this manual” and “the requirements of safety on site and environment”.

## 1. The following should always be observed for safety

- Please provide an exclusive circuit for the air conditioner and do not connect other electrical appliances to it.
- Be sure to read “The following should always be observed for safety” before installing the air conditioner.
- Be sure to observe the cautions specified here as they include important items related to safety.
- The indications and meanings are as follows.

**⚠ Warning:**  
Could lead to death, serious injury, etc.





**⚠ Caution:**  
Could lead to serious injury in particular environments when operated incorrectly.

- After reading this manual, be sure to keep it together with the instruction manual in a handy place on the customer’s site.

**⚡** : Indicates a part which must be grounded.

**⚠ Warning:**  
Carefully read the labels affixed to the main unit.  
**Ⓞ** : Indicates warnings and cautions when using R32 refrigerant.

## MEANINGS OF SYMBOLS DISPLAYED ON THE UNIT

|   |   |   |
|---|---|---|
|  | <b>WARNING</b><br>(Risk of fire)  | This mark is for R32 refrigerant only. Refrigerant type is written on nameplate of outdoor unit. In case that refrigerant type is R32, this unit uses a flammable refrigerant. If refrigerant leaks and comes in contact with fire or heating part, it will create harmful gas and there is risk of fire. |
|  | Read the OPERATION MANUAL carefully before operation.   |   |
|  | Service personnel are required to carefully read the OPERATION MANUAL and INSTALLATION MANUAL before operation. |   |
|  | Further information is available in the OPERATION MANUAL, INSTALLATION MANUAL, and the like.                    |   |

- ⚠ Warning:**
- Do not install it by yourself (customer). Incomplete installation could cause injury due to fire, electric shock, the unit falling or leakage of water. Consult the dealer from whom you purchased the unit or special installer.
  - Servicing shall be performed only as recommended by the manufacturer.
  - For installation and relocation work, follow the instructions in the Installation Manual and use tools and pipe components specifically made for use with R32 refrigerant. If pipe components not designed for R32 refrigerant are used and the unit is not installed correctly, the pipes may burst and cause damage or injuries. In addition, water leakage, electric shock, or fire may result.
  - Do not alter the unit. It may cause fire, electric shock, injury or water leakage.
  - This appliance is intended to be used by expert or trained users in shops, in light industry and on farms, or for commercial use by lay persons.
  - Install the unit securely in a place which can bear the weight of the unit. When installed in an insufficient strong place, the unit could fall causing injured.
  - Use the specified wires to connect the indoor and outdoor units securely and attach the wires firmly to the terminal board connecting sections so the stress of the wires is not applied to the sections. Incomplete connecting and fixing could cause fire.
  - Do not use intermediate connection of the power cord or the extension cord and do not connect many devices to one AC outlet. It could cause a fire or an electric shock due to defective contact, defective insulation, exceeding the permissible current, etc.
  - Check that the refrigerant gas does not leak after installation has completed.
  - Perform the installation securely referring to the installation manual. Incomplete installation could cause a personal injury due to fire, electric shock, the unit falling or leakage of water.
  - Use only specified cables for wiring. The wiring connections must be made securely with no tension applied on the terminal connections. Also, never splice the cables for wiring (unless otherwise indicated in this document). Failure to observe these instructions may result in overheating or a fire.
  - If the supply cord is damaged, it must be replaced by the manufacturer, its service agent or similarly qualified persons in order to avoid hazard.
  - The appliance shall be installed in accordance with national wiring regulations.
  - Perform electrical work according to the installation manual and be sure to use an exclusive circuit. If the capacity of the power circuit is insufficient or there is incomplete electrical work, it could result in a fire or an electric shock.
  - Attach the electrical part cover to the indoor unit and the service panel to the outdoor unit securely. If the electrical part cover in the indoor unit and/or the service panel in the outdoor unit are not attached securely, it could result in a fire or an electric shock due to dust, water, etc.
  - Be sure to use the part provided or specified parts for the installation work. The use of defective parts could cause an injury or leakage of water due to a fire, an electric shock, the unit falling, etc.
  - Ventilate the room if refrigerant leaks during operation. If the refrigerant comes in contact with a flame, poisonous gases will be released.
  - When pumping down the refrigerant, stop the compressor before disconnecting the refrigerant pipes. The compressor may burst if air etc. get into it.

# 1. The following should always be observed for safety

**⚠ Warning:**

- When installing or relocating, or servicing the air conditioner, use only the specified refrigerant (R32) to charge the refrigerant lines. Do not mix it with any other refrigerant and do not allow air to remain in the lines. If air is mixed with the refrigerant, then it can be the cause of abnormal high pressure in the refrigerant line, and may result in an explosion and other hazards. The use of any refrigerant other than that specified for the system will cause mechanical failure or system malfunction or unit breakdown. In the worst case, this could lead to a serious impediment to securing product safety.
- Do not use means to accelerate the defrosting process or to clean, other than those recommended by the manufacturer.
- The appliance shall be stored in a room without continuously operating ignition sources (for example: open flames, an operating gas appliance or an operating electric heater).
- Do not pierce or burn.
- Be aware that refrigerants may not contain an odour.
- ⊙ Pipe-work shall be protected from physical damage.
- The installation of pipe-work shall be kept to a minimum.
- Compliance with national gas regulations shall be observed.
- Keep any required ventilation openings clear of obstruction.

- ⊙ Do not use low temperature solder alloy in case of brazing the refrigerant pipes.
- ⊙ When performing brazing work, be sure to ventilate the room sufficiently. Make sure that there are no hazardous or flammable materials nearby. When performing the work in a closed room, small room, or similar location, make sure that there are no refrigerant leaks before performing the work. If refrigerant leaks and accumulates, it may ignite or poisonous gases may be released.
- ⊙ The appliance shall be stored in a well-ventilated area where the room size corresponds to the room area as specified for operation.
- ⊙ Keep gas-burning appliances, electric heaters, and other fire sources (ignition sources) away from the location where installation, repair, and other air conditioner work will be performed. If refrigerant comes into contact with a flame, poisonous gases will be released.
- ⊙ Do not smoke during work and transportation.

**⚠ Caution:**

- Perform grounding. Do not connect the ground wire to a gas pipe, water pipe arrester or telephone ground wire. Defective grounding could cause an electric shock.
- Do not install the unit in a place where an inflammable gas leaks. If gas leaks and accumulates in the area surrounding the unit, it could cause an explosion.
- Install a ground leakage breaker depending on the installation place (where it is humid). If a ground leakage breaker is not installed, it could cause an electric shock.

- Perform the drainage/piping work securely according to the installation manual. If there is a defect in the drainage/piping work, water could drop from the unit and household goods could be wet and damaged.
- Fasten a flare nut with a torque wrench as specified in this manual. When fastened too tight, a flare nut may broken after a long period and cause a leakage of refrigerant.

## 2. Selecting the installation location

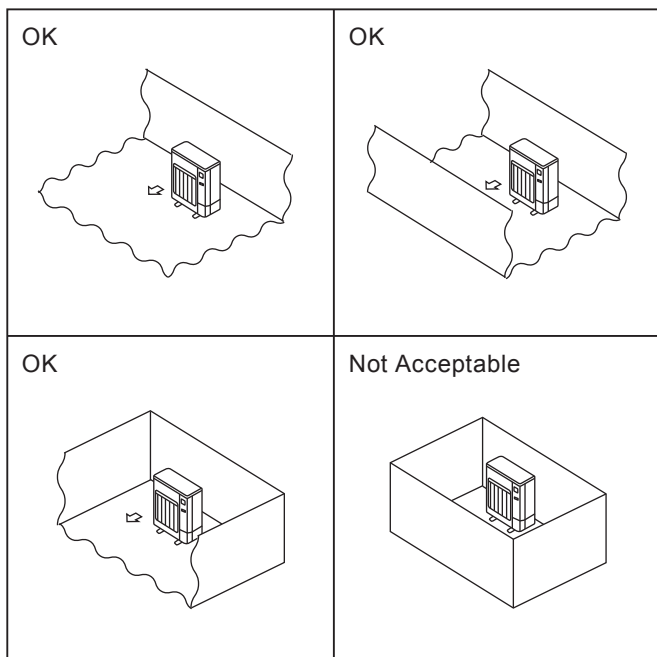

Fig. 2-1

### 2.1. Outdoor unit

- R32 is heavier than air—as well as other refrigerants—so tends to accumulate at the base (in the vicinity of the floor). If R32 accumulates around base, it may reach a flammable concentration in case room is small. To avoid ignition, maintaining a safe work environment is required by ensuring appropriate ventilation. If a refrigerant leak is confirmed in a room or an area where there is insufficient ventilation, refrain from using of flames until the work environment can be improved by ensuring appropriate ventilation.
- Where it is not exposed to strong wind.
- Where airflow is good and dustless.
- Where it is not exposed to rain and direct sunshine.
- Where neighbours are not annoyed by operation sound or hot air.
- Where rigid wall or support is available to prevent the increase of operation sound or vibration.
- Where there is no risk of combustible gas leakage.
- When installing the unit at a high level, be sure to fix the unit legs.
- Where it is at least 3 m away from the antenna of TV set or radio. (Otherwise, images would be disturbed or noise would be generated.)
- Please install it in an area not affected by snowfall or blowing snow. In areas with heavy snow, please install a canopy, a pedestal and/or some baffle boards.
- Install the unit horizontally.
- Refrigerant pipes connection shall be accessible for maintenance purposes.
- ⊙ Install outdoor units in a place where at least one of the four sides is open, and in a sufficiently large space without depressions. (Fig. 2-1)

**⚠ Caution:**

Avoid the following places for installation where air conditioner trouble is liable to occur.

- Where there is too much machine oil.
- Salty environment as seaside areas.
- Hot-spring areas.
- Where sulfide gas exists.
- Other special atmospheric areas.

The outdoor unit produces condensate during the heating operation. Select the installation place to ensure to prevent the outdoor unit and/or the grounds from being wet by drain water or damaged by frozen drain water.

## 2. Selecting the installation location

### 2.2. Minimum installation area

If you unavoidably install a unit in a space where all four sides are blocked or there are depressions, confirm that one of these situations (A, B or C) is satisfied.

**Note: These countermeasures are for keeping safety not for specification guarantee.**

A) Secure sufficient installation space (minimum installation area  $A_{min}$ ).

Install in a space with an installation area of  $A_{min}$  or more, corresponding to refrigerant quantity  $M$  (factory-charged refrigerant + locally added refrigerant).

| M [kg] | $A_{min}$ [m <sup>2</sup> ] |
|--------|-----------------------------|
| 1.0    | 12                          |
| 1.5    | 17                          |
| 2.0    | 23                          |
| 2.5    | 28                          |
| 3.0    | 34                          |
| 3.5    | 39                          |
| 4.0    | 45                          |
| 4.5    | 50                          |
| 5.0    | 56                          |
| 5.5    | 62                          |
| 6.0    | 67                          |
| 6.5    | 73                          |
| 7.0    | 78                          |
| 7.5    | 84                          |

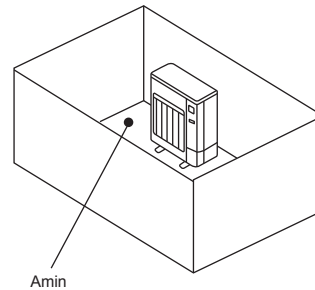

M: Refrigerant amount (factory-charged refrigerant + locally added refrigerant) [kg]  
 $A_{min}$ : Minimum installation area [m<sup>2</sup>]

B) Install in a space with a depression height of  $\leq 0.125$  [m].

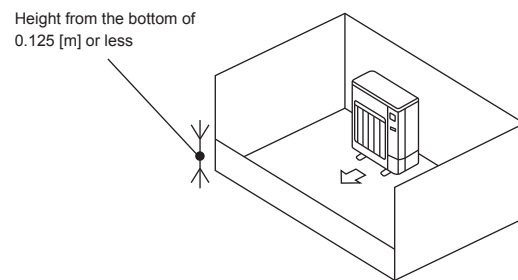
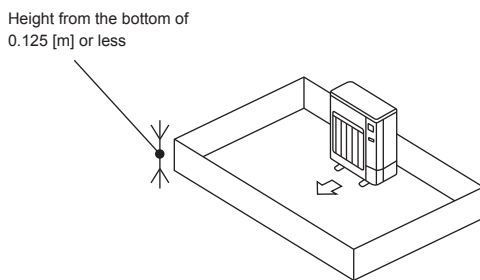

C) Create an appropriate ventilation open area.

Make sure that the width of the open area is 0.9 [m] or more and the height of the open area is 0.15 [m] or more.

However, the height from the bottom of the installation space to the bottom edge of the open area should be 0.125 [m] or less.

Open area should be 75% or more opening.

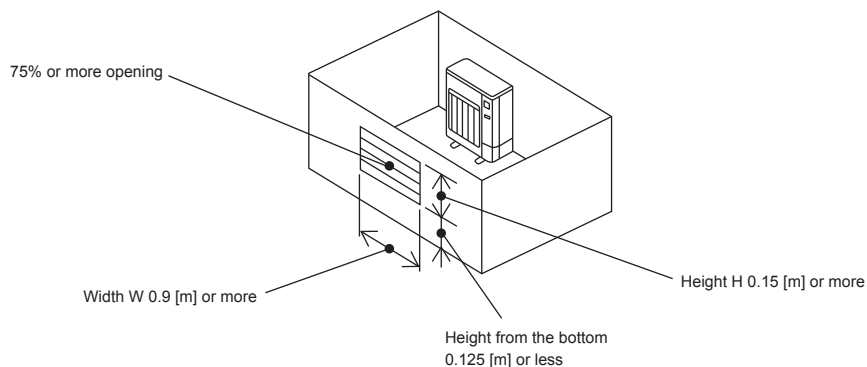

## 2. Selecting the installation location

### ■ Indoor units

Install in a room with a floor area of  $A_{min}$  or more, corresponding to refrigerant quantity  $M$  (factory-charged refrigerant + locally added refrigerant).

\* For the factory-charged refrigerant amount, refer to the spec nameplate or installation manual.

For the amount to be added locally, refer to the installation manual.

Install the indoor unit so that the height from the floor to the bottom of the indoor unit is  $h_0$ ;

for wall mounted: 1.8 m or more;

for ceiling suspended, cassette and ceiling concealed: 2.2 m or more.

\* There are restrictions in installation height for each model, so read the installation manual for the particular unit.

| M [kg] | $A_{min}$ [m <sup>2</sup> ] |
|--------|-----------------------------|
| 1.0    | 4                           |
| 1.5    | 6                           |
| 2.0    | 8                           |
| 2.5    | 10                          |
| 3.0    | 12                          |
| 3.5    | 14                          |
| 4.0    | 16                          |
| 4.5    | 20                          |
| 5.0    | 24                          |
| 5.5    | 29                          |
| 6.0    | 35                          |
| 6.5    | 41                          |
| 7.0    | 47                          |
| 7.5    | 54                          |

M: Refrigerant amount (factory-charged refrigerant + locally added refrigerant) [kg]

$A_{min}$ : Minimum installation area [m<sup>2</sup>]

<Wall mounted>

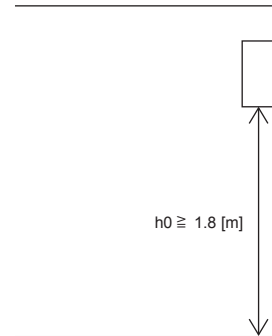

<Ceiling suspended>

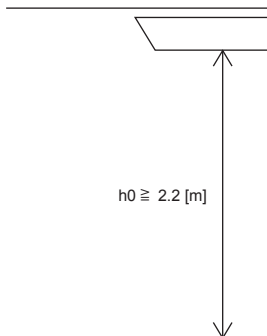

<Cassette>

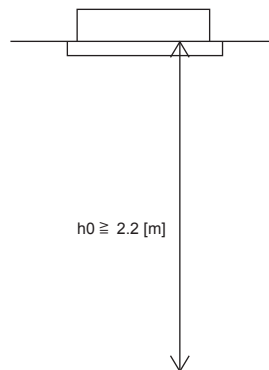

<Ceiling concealed>

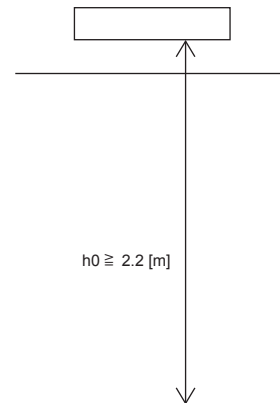

In case of using dampers with ceiling concealed type indoor unit, please check the following to calculate  $A_{min}$ :

Case 1: When there is no common zone (the area without dampers)

- The area of each room must be  $A_{min}$  or larger. (See Fig. 2-2)

Case 2: When there is a common zone (the area without dampers)

- The area of each room including the common zone must be  $A_{min}$  or larger. (See Fig. 2-3)

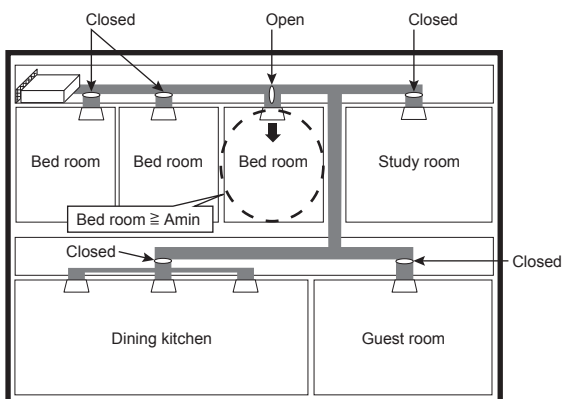

**Fig. 2-2**  
No common zone

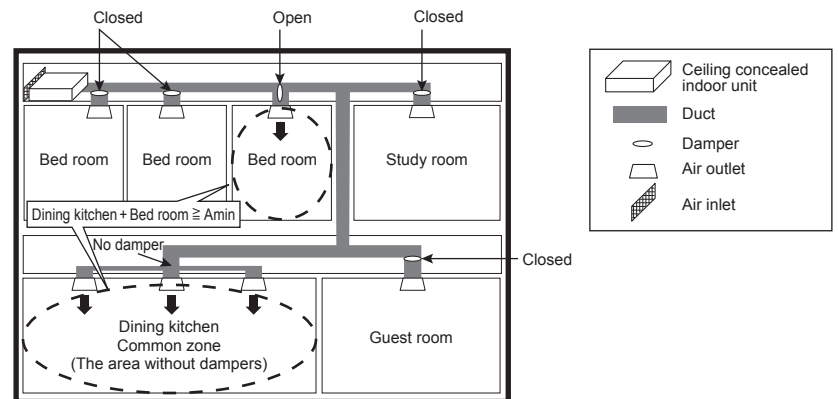

**Fig. 2-3**  
With a common zone

### 3. Installation diagram

■ M25  
M35

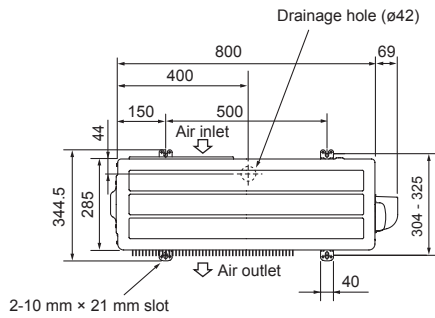
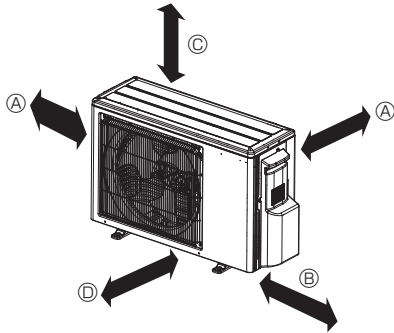

■ M50

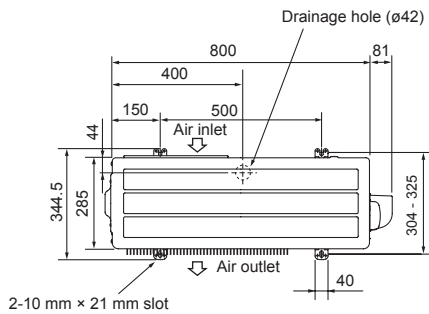
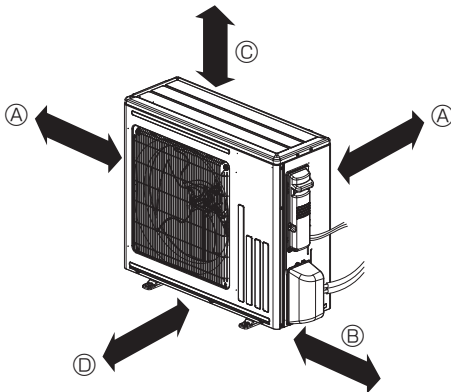

#### 3.1. Outdoor unit (Fig. 3-1)

##### Ventilation and service space

■ M25

M35

M50

Ⓐ 100 mm or more

Ⓑ 350 mm or more

Ⓒ Basically open 100 mm or more without any obstruction in front and on both sides of the unit.

Ⓓ 200 mm or more (Open two sides of left, right, or rear side.)

■ M60

M71

Ⓐ 100 mm or more

Ⓑ 350 mm or more

Ⓒ 500 mm or more

When the piping is to be attached to a wall containing metals (tin plated) or metal netting, use a chemically treated wooden piece 20 mm or thicker between the wall and the piping or wrap 7 to 8 turns of insulation vinyl tape around the piping.

Units should be installed by licensed contractor accordingly to local code requirement.

(mm)

##### Note:

**When operating the air conditioner in low outside temperature, be sure to follow the instructions described below.**

- Never install the outdoor unit in a place where its air inlet/outlet side may be exposed directly to wind.
- To prevent exposure to wind, install the outdoor unit with its air inlet side facing the wall.
- To prevent exposure to wind, it is recommended to install a baffle board on the air outlet side of the outdoor unit.

■ M60

M71

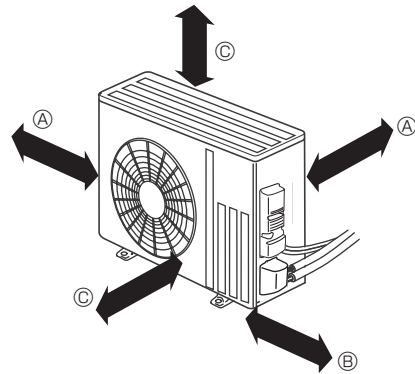

(mm)

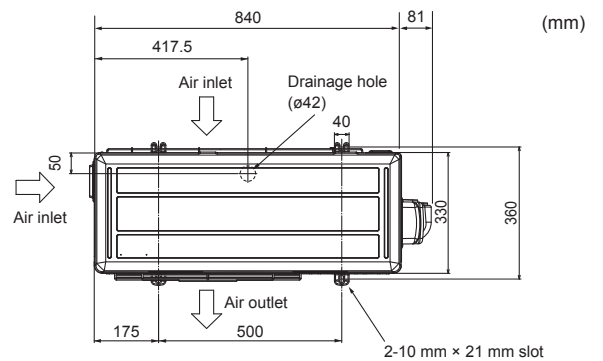

Fig. 3-1

## 4. Drain piping for outdoor unit (Fig. 4-1)

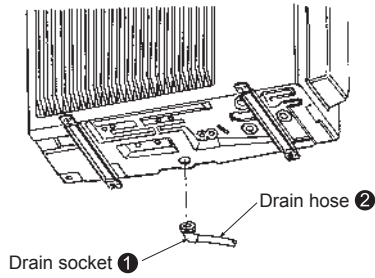

Fig. 4-1

### 4.1. Accessories

Check the following parts before installation.

<Outdoor unit>

|   |              |   |
|---|--------------|---|
| ① | Drain socket | 1 |
|---|--------------|---|

- Provide drain piping before indoor and outdoor piping connection. (It will be hard to install drain socket ① if indoor and outdoor piping connection is conducted prior to drain piping as outdoor unit becomes immovable.)
- Connect the drain hose ② (obtainable at a store, inside diameter: 15 mm) as shown in the figure for drainage.
- Make sure to provide drain piping with a downhill grade for easy drain flow.

**Note:**

Do not use the drain socket ① in the cold region. Drain may freeze and it makes the fan stop.

## 5. Refrigerant piping work

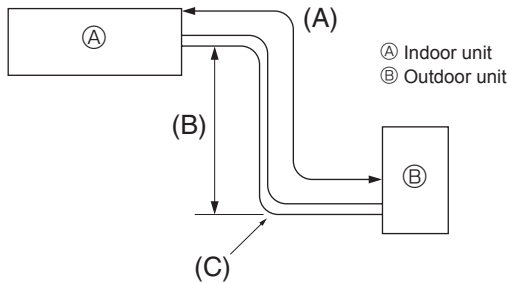

Fig. 5-1

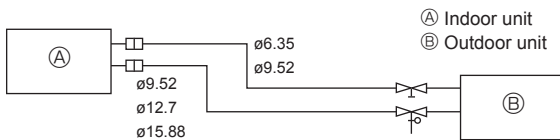

Fig. 5-2

### 5.1. Refrigerant pipe (Fig. 5-1)

► Check that the difference between the heights of the indoor and outdoor units, the length of refrigerant pipe, and the number of bends in the pipe are within the limits shown below.

| Models      | (A) Pipe length (one way) | (B) Height difference | (C) Number of bends (one way) |
|-------------|---------------------------|-----------------------|-------------------------------|
| M25/M35     | Max. 20 m                 | Max. 12 m             | Max. of 10                    |
| M50/M60/M71 | Max. 30 m                 | Max. 30 m             | Max. of 10                    |

- Height difference limitations are binding regardless of which unit, indoor or outdoor, is positioned higher.
- Refrigerant adjustment ... If pipe length exceeds 7 m, additional refrigerant (R32) charge is required.

(The outdoor unit is charged with refrigerant for pipe length up to 7 m.)

| Pipe length             | Up to 7 m     | No additional charge is required.                                | Maximum amount of refrigerant |
|-------------------------|---------------|--|-------------------------------|
|                         | Exceeding 7 m | Additional charge is required. (Refer to the table below.)       |                               |
| Refrigerant to be added | M25           | $20 \text{ g} \times (\text{refrigerant piping length (m)} - 7)$ | 0.91                          |
|                         | M35           | $20 \text{ g} \times (\text{refrigerant piping length (m)} - 7)$ | 1.16                          |
|                         | M50           | $20 \text{ g} \times (\text{refrigerant piping length (m)} - 7)$ | 1.66                          |
|                         | M60           | $20 \text{ g} \times (\text{refrigerant piping length (m)} - 7)$ | 1.71                          |
|                         | M71           | $40 \text{ g} \times (\text{refrigerant piping length (m)} - 7)$ | 2.37                          |

(1) Table below shows the specifications of pipes commercially available.

| Model | Pipe       | Outside diameter |      | Min. wall thickness | Insulation thickness | Insulation material                                |
|-------|------------|------------------|------|---------------------|----------------------|--|
|       |            | mm               | inch |                     |                      |  |
| M25   | For liquid | 6.35             | 1/4  | 0.8 mm              | 8 mm                 | Heat resisting foam plastic 0.045 specific gravity |
|       | For gas    | 9.52             | 3/8  | 0.8 mm              | 8 mm                 |  |
| M35   | For liquid | 6.35             | 1/4  | 0.8 mm              | 8 mm                 |  |
|       | For gas    | 9.52             | 3/8  | 0.8 mm              | 8 mm                 |  |
| M50   | For liquid | 6.35             | 1/4  | 0.8 mm              | 8 mm                 |  |
|       | For gas    | 12.7             | 1/2  | 0.8 mm              | 8 mm                 |  |
| M60   | For liquid | 6.35             | 1/4  | 0.8 mm              | 8 mm                 |  |
|       | For gas    | 15.88            | 5/8  | 0.8 mm              | 8 mm                 |  |
| M71   | For liquid | 9.52             | 3/8  | 0.8 mm              | 8 mm                 |  |
|       | For gas    | 15.88            | 5/8  | 1.0 mm              | 8 mm                 |  |

(2) Ensure that the 2 refrigerant pipes are well insulated to prevent condensation.

(3) Refrigerant pipe bending radius must be 100 mm or more.

**⚠ Caution:**

Using careful insulation of specified thickness. Excessive thickness prevents storage behind the indoor unit and smaller thickness causes dew dripage.

- Be sure to have appropriate ventilation in order to prevent ignition. Furthermore, be sure to carry out fire prevention measures that there are no dangerous or flammable objects in the surrounding area.
- R32 maintenance refilling: Before servicing refilling the equipment with R32 to ensure that there is no risk of explosion from electrical sparks it must be ensured that the equipment machine is 100% disconnected from the mains supply.

## 5. Refrigerant piping work

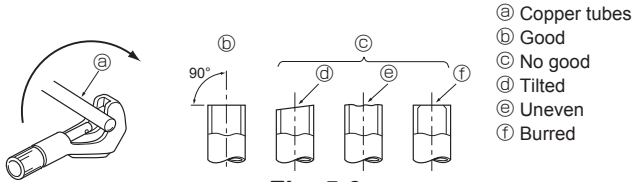

Fig. 5-3

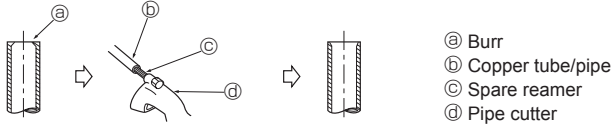

Fig. 5-4

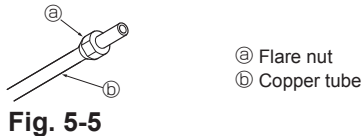

Fig. 5-5

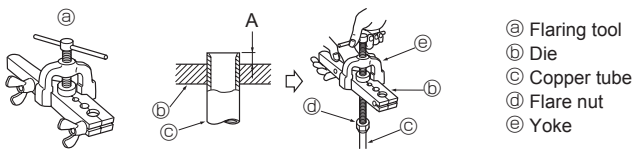

Fig. 5-6

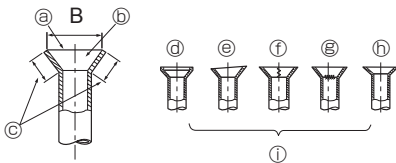

Fig. 5-7

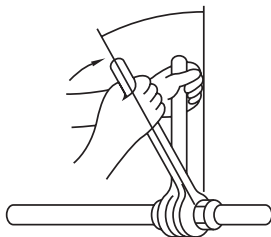

Fig. 5-8

- Ⓐ Copper tubes
- Ⓑ Good
- Ⓒ No good
- Ⓓ Tilted
- Ⓔ Uneven
- Ⓕ Burred

- Ⓐ Burr
- Ⓑ Copper tube/pipe
- Ⓒ Spare reamer
- Ⓓ Pipe cutter

- Ⓐ Flare nut
- Ⓑ Copper tube

- Ⓐ Flaring tool
- Ⓑ Die
- Ⓒ Copper tube
- Ⓓ Flare nut
- Ⓔ Yoke

### 5.2. Flaring work

- Main cause of gas leakage is defect in flaring work.
- Carry out correct flaring work in the following procedure.

#### 5.2.1. Pipe cutting (Fig. 5-3)

- Using a pipe cutter cut the copper tube correctly.

#### 5.2.2. Burrs removal (Fig. 5-4)

- Completely remove all burrs from the cut cross section of pipe/tube.
- Put the end of the copper tube/pipe to downward direction as you remove burrs in order to avoid burrs drop in the tubing.

#### 5.2.3. Putting nut on (Fig. 5-5)

- Remove flare nuts attached to indoor and outdoor unit, then put them on pipe/tube having completed burr removal.
- (not possible to put them on after flaring work)

#### 5.2.4. Flaring work (Fig. 5-6)

- Carry out flaring work using flaring tool as shown at the right.

| Pipe diameter<br>(mm) | Dimension                     |                                      |
|-----------------------|-------------------------------|--------------------------------------|
|                       | A (mm)                        | B <sup>+0</sup> <sub>-0.4</sub> (mm) |
|                       | When the tool for R32 is used |                                      |
|                       | Clutch type                   |                                      |
| 6.35                  | 0 - 0.5                       | 9.1                                  |
| 9.52                  | 0 - 0.5                       | 13.2                                 |
| 12.7                  | 0 - 0.5                       | 16.6                                 |
| 15.88                 | 0 - 0.5                       | 19.7                                 |

Firmly hold copper tube in a die in the dimension shown in the table at above.

#### 5.2.5. Check (Fig. 5-7)

- Compare the flared work with a figure in right side hand.
- If flare is noted to be defective, cut off the flared section and do flaring work again.

- Ⓐ Smooth all around
- Ⓑ Inside is shining without any scratches
- Ⓒ Even length all around
- Ⓓ Too much
- Ⓔ Tilted
- Ⓕ Scratch on flared plane
- Ⓖ Cracked
- Ⓗ Uneven
- Ⓘ Bad examples

- Apply a thin coat of refrigeration oil on the seat surface of pipe. (Fig. 5-8)
- For connection first align the center, then tighten the first 3 to 4 turns of flare nut.
- Use tightening torque table below as a guideline for indoor unit side union joint section, and tighten using two wrenches. Excessive tightening damages the flare section.

| Copper pipe O.D.<br>(mm) | Flare nut O.D.<br>(mm) | Tightening torque<br>(N·m) |
|--------------------------|------------------------|----------------------------|
| ø6.35                    | 17                     | 14 - 18                    |
| ø9.52                    | 22                     | 34 - 42                    |
| ø12.7                    | 26                     | 49 - 61                    |
| ø15.88                   | 29                     | 68 - 82                    |

#### ⚠ Warning:

When installing the unit, securely connect the refrigerant pipes before starting the compressor.

#### ⚠ Warning:

Be careful of flying flare nut! (Internally pressurized)

Remove the flare nut as follows:

1. Loosen the nut until you hear a hissing noise.
2. Do not remove the nut until the gas has been completely released (i.e., hissing noise stops).
3. Check that the gas has been completely released, and then remove the nut.



## 5. Refrigerant piping work

### 5.3. Purging procedures leak test

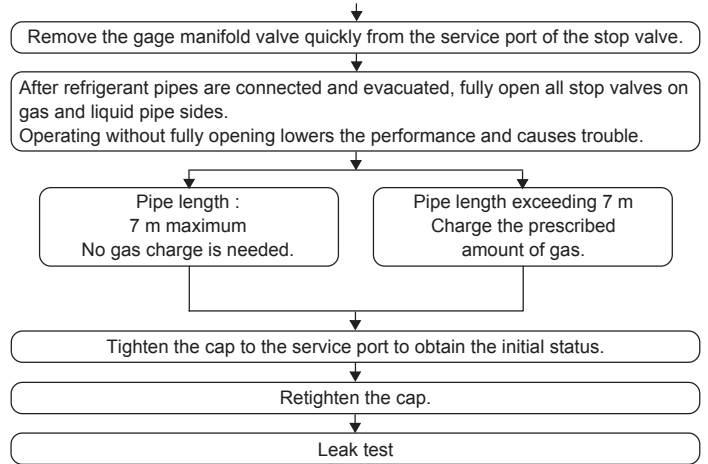
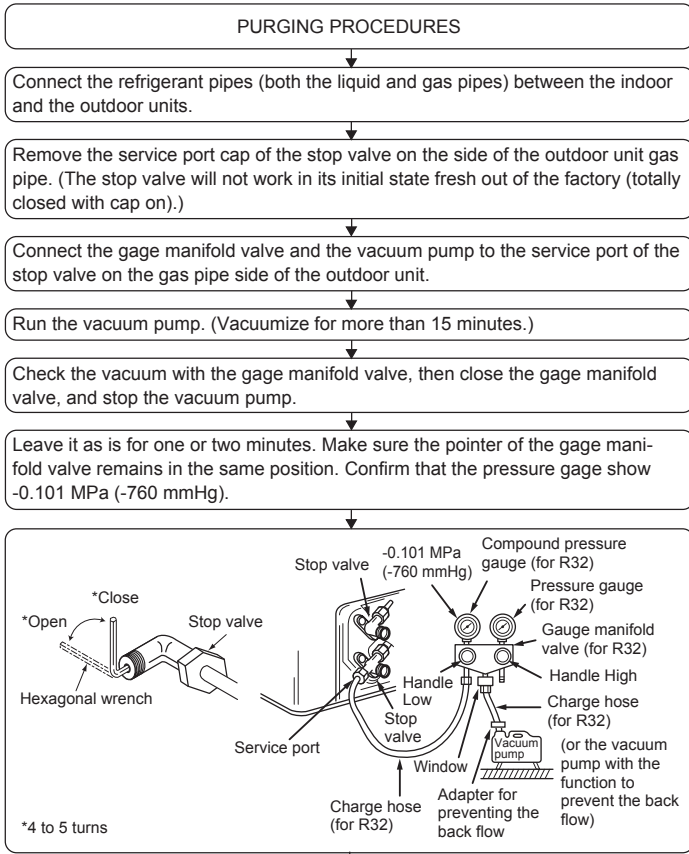

## 6. Electrical work

### 6.1. Outdoor unit (Fig. 6-1, Fig. 6-2, Fig. 6-3, Fig. 6-4, Fig. 6-5)

- ① Remove the service panel.
- ② Wire the cables referring to the Fig. 6-1, Fig. 6-2, Fig. 6-3, Fig. 6-4 and the Fig. 6-5.

#### ■ M25/35/50

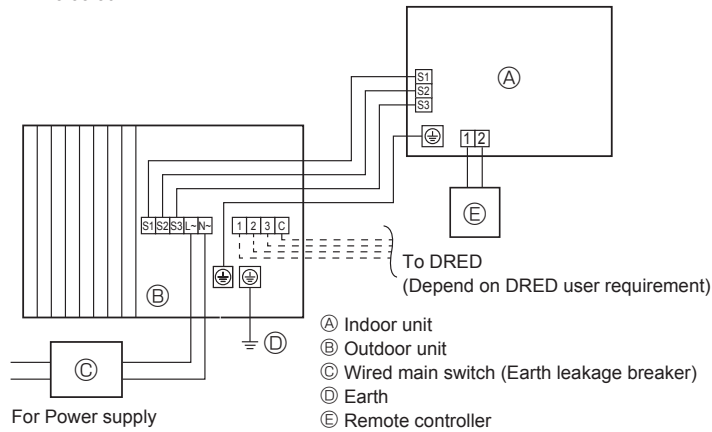

DRED wire connection is described on page 10.

**Fig. 6-1**

#### ■ M60/71

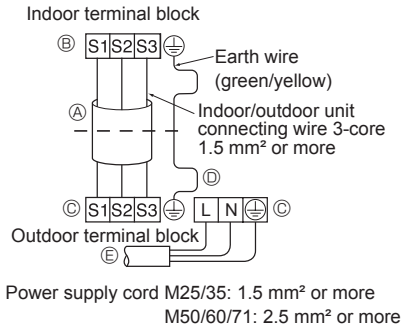
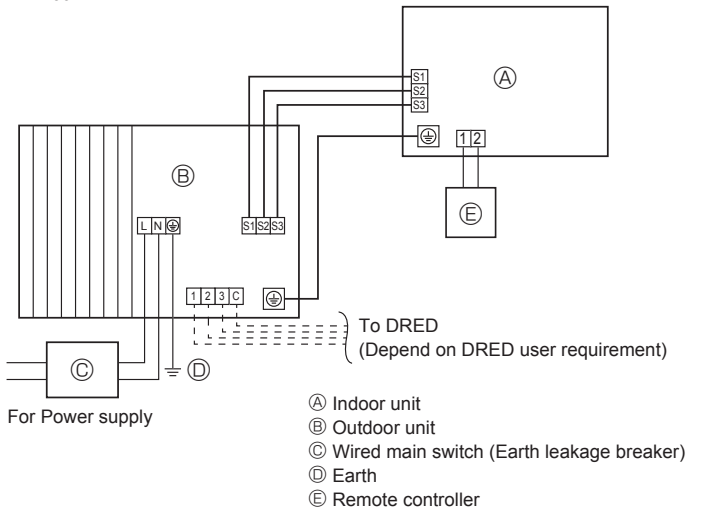

**Fig. 6-2**

#### ■ M25/35

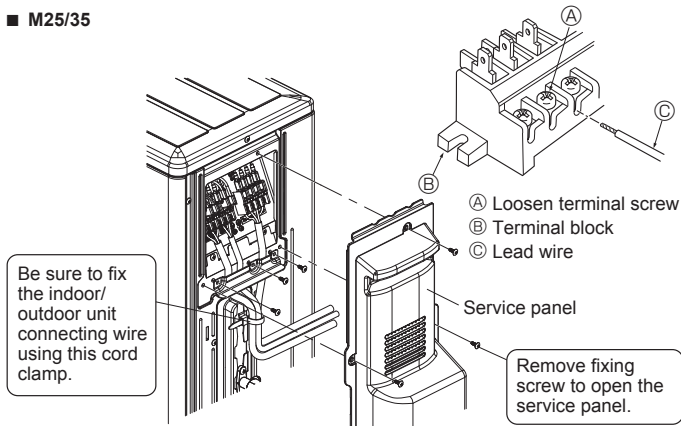

**Fig. 6-3**

#### ■ M50

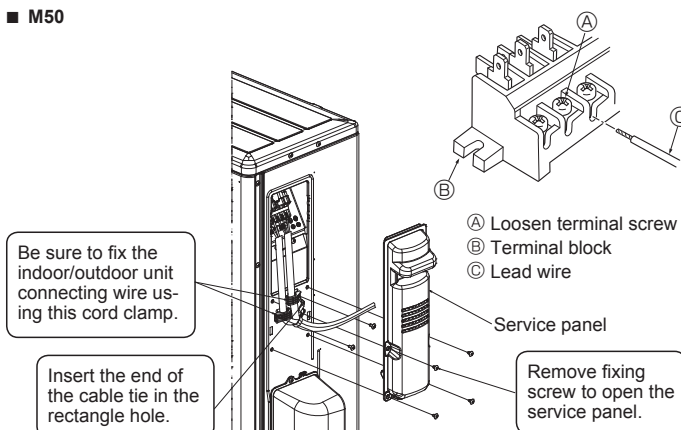

**Fig. 6-4**

- Perform wiring as shown in the diagram to the lower left. (Procure the cable locally) (Fig. 6-2)

Make sure to use cables of the correct polarity only.

- ① Connecting cable
- ② Indoor terminal block
- ③ Outdoor terminal block
- ④ Always install an earth wire longer than other cables.
- ⑤ Power supply cord
- ⑥ Lead wire

- Make earth wire a little longer than others. (More than 100 mm)
- For future servicing, give extra length to the connecting wires.
- Be sure to attach each screw to its correspondent terminal when securing the cord and/or the wire to the terminal block.

- Connect cable from the indoor unit correctly on the terminal-block.
- Use the same terminal block and polarity as is used with the indoor unit.
- For aftercare maintenance, give extra length to connecting cable.

- Both end of connecting cable (extension wire) are peeled off. When too long, or connected by cutting off the middle, peel off power supply cable to the size given in the figure.
- Be careful not to contact connecting cable with piping.

#### ⚠ Caution:

- Use care not to make miswiring.
- Firmly tighten the terminal screws to prevent them from loosening.
- After tightening, pull the wires lightly to confirm that they do not move.

#### ⚠ Warning:

- Be sure to attach the service panel of the outdoor unit securely. If it is not attached correctly, it could result in a fire or an electric shock due to dust, water, etc.
- Tighten terminal screws securely.
- Wiring should be done so that the power lines are not subject to tension. Otherwise, heat may be generated or fire may occur.

## 6. Electrical work

### ■ M60/71

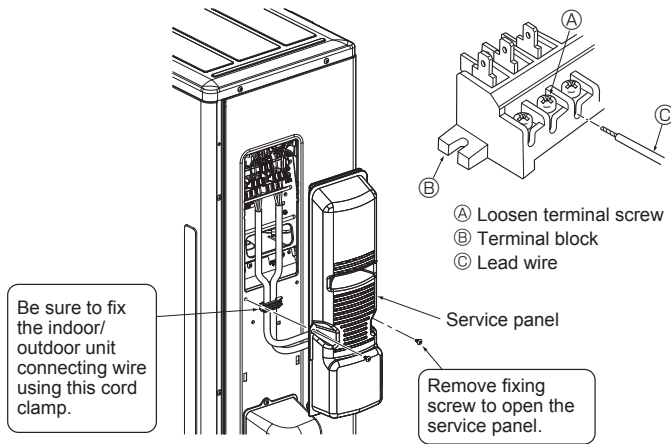
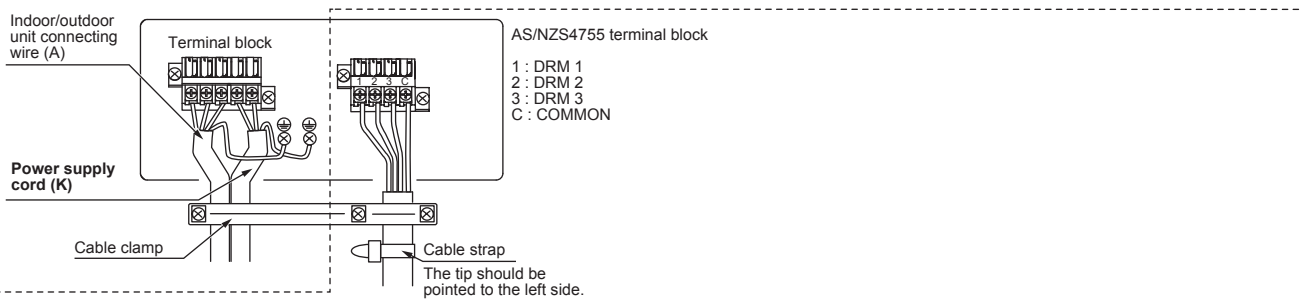

Fig. 6-5

## 6.2. Connecting wires for DRED

### ■ M25/35



This unit has demand response capability which is compliant with AS/NZS 4755.3.1. To activate this function, you need to make a contract with remote agents such as electric supply company, then this unit should be connected to Demand response enabling devise (DRED). For further information, consult your dealer. This unit supports 3 Demand Response Modes (DRMs): DRM1, DRM2 and DRM3.

### ■ M50

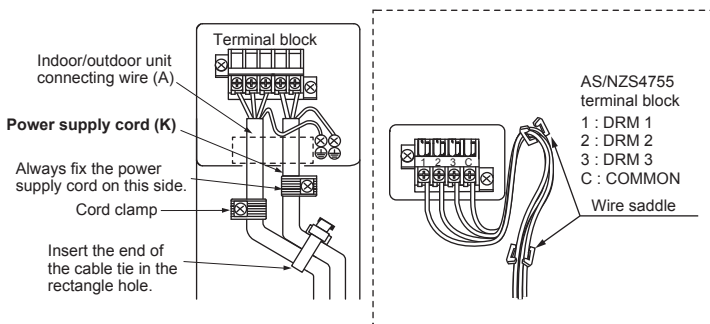

This unit has demand response capability which is compliant with AS/NZS 4755.3.1. To activate this function, you need to make a contract with remote agents such as electric supply company, then this unit should be connected to Demand response enabling devise (DRED). For further information, consult your dealer. This unit supports 3 Demand Response Modes (DRMs): DRM1, DRM2 and DRM3.

### ⚠ Caution:

- To prevent malfunction caused by noise, route the cord connecting this unit to DRED and the power supply cord as parallel as possible.
- Do not connect the demand control transmission cable to the terminal block for power supply.
- Do not pull, extremely bend or apply strong pressure on the wire to prevent failure.
- Do not screw DRED to outdoor unit.
- Do not put DRED in outdoor unit.
- Secure electrical wiring above clamp.
- Do not get DRED wire caught in the service panel.
- Secure the power supply cord, indoor/outdoor unit connecting wire and DRED wire with the Cable clamp and Cable strap.

## 6. Electrical work

### ■ M60/71

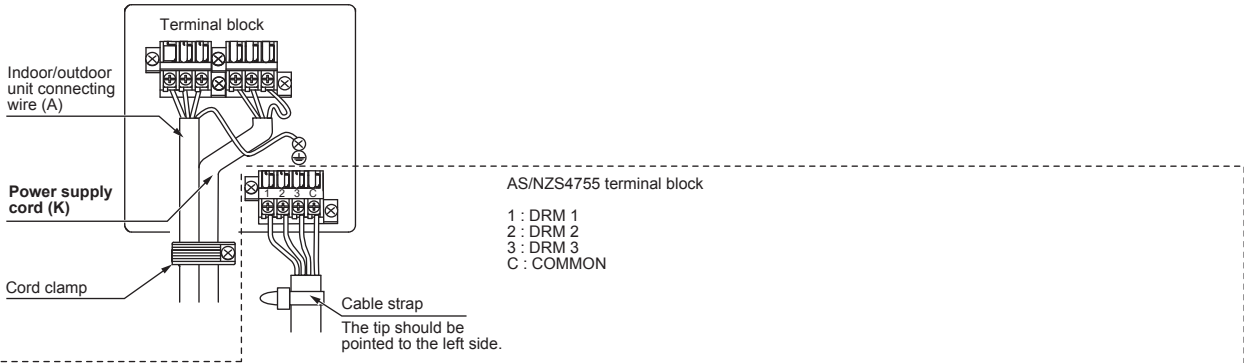

This unit has demand response capability which is compliant with AS/NZS 4755.3.1. To activate this function, you need to make a contract with remote agents such as electric supply company, then this unit should be connected to Demand response enabling device (DRED). For further information, consult your dealer. This unit supports 3 Demand Response Modes (DRMs): DRM1, DRM2 and DRM3.

#### ⚠ Caution:

- To prevent malfunction caused by noise, route the cord connecting this unit to DRED and the power supply cord as parallel as possible.
- Do not connect the demand control transmission cable to the terminal block for power supply.
- Do not pull, extremely bend or apply strong pressure on the wire to prevent failure.
- Do not screw DRED to outdoor unit.
- Do not put DRED in outdoor unit.
- Secure electrical wiring above clamp.
- Do not get DRED wire caught in the service panel.
- Secure the outdoor unit connecting DRED wire with cable strap.
- Secure the power supply cord and indoor/outdoor unit connecting wire with cord clamp.

- Make earth wire a little longer than others. (More than 100 mm)
- For future servicing, give extra length to the connecting wires.
- Be sure to attach each screw to its correspondent terminal when securing the cord and/or the wire to the terminal block.

## 6. Electrical work

### 6.3. Field electrical wiring

| Outdoor unit model                                |                                 | M25/35                    | M50/60/71                 |
|---|---------------------------------|---------------------------|---------------------------|
| Outdoor unit power supply                         |                                 | ~N (single), 50 Hz, 230 V | ~N (single), 50 Hz, 230 V |
| Outdoor unit input capacity Main switch (Breaker) |                                 | *1                        | 20 A                      |
| Wiring<br>Wire No. x<br>size (mm <sup>2</sup> )   | Outdoor unit power supply       | 2 × Min. 1.5              | 2 × Min. 2.5              |
|   | Outdoor unit power supply earth | 1 × Min. 1.5              | 1 × Min. 2.5              |
|   | Indoor unit-Outdoor unit        | 3 × 1.5 (Polar)           | 3 × 1.5 (Polar)           |
|   | Indoor unit-Outdoor unit earth  | 1 × Min. 1.5              | 1 × Min. 1.5              |
| Circuit<br>rating                                 | Outdoor unit L-N                | *2                        | 230 VAC                   |
|   | Indoor unit-Outdoor unit S1-S2  | *2                        | 230 VAC                   |
|   | Indoor unit-Outdoor unit S2-S3  | *2                        | 12 VDC – 24 VDC           |

\*1. A breaker with at least 3 mm contact separation in each poles shall be provided. Use earth leakage breaker (NV).

Make sure that the current leakage breaker is one compatible with higher harmonics.

Always use a current leakage breaker that is compatible with higher harmonics as this unit is equipped with an inverter.

The use of an inadequate breaker can cause the incorrect operation of inverter.

\*2. The figures are NOT always against the ground.

S3 terminal has 24 VDC against S2 terminal. However between S3 and S1, these terminals are NOT electrically insulated by the transformer or other device.

**Notes:** 1. Wiring size must comply with the applicable local and national code.

2. Power supply cords and Indoor/Outdoor unit connecting cords shall not be lighter than polychloroprene sheathed flexible cord. (Design 60245 IEC 57)

3. Install an earth longer than other cables.

4. Use self-extinguishing distribution cables for power supply wiring.

5. Properly route wiring so as not to contact the sheet metal edge or a screw tip.

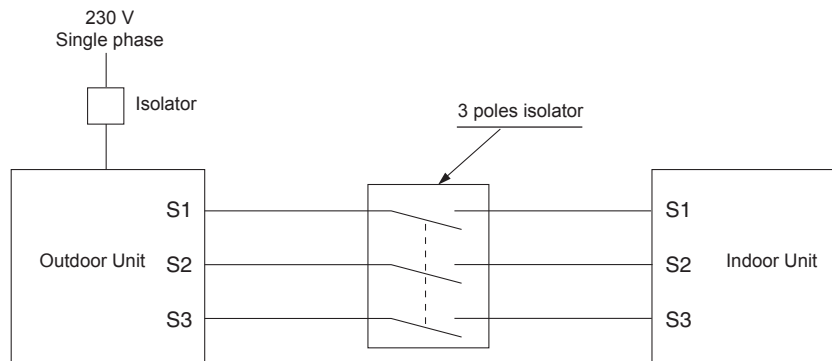

#### Warning:

There is high voltage potential on the S3 terminal caused by electrical circuit design that has no electrical insulation between power line and communication signal line. Therefore, please turn off the main power supply when servicing. And do not touch the S1, S2, S3 terminals when the power is energized. If isolator should be used between indoor unit and outdoor unit, please use 3-poles type.

Never splice the power cable or the indoor-outdoor connection cable, otherwise it may result in a smoke, a fire or communication failure.

Be sure to connect the indoor-outdoor connecting cables directly to the units (no intermediate connections).

Intermediate connections can lead to communication error if water enters the cables and causes insufficient insulation to ground or a poor electrical contact at the intermediate connection point.

## 7. Maintenance

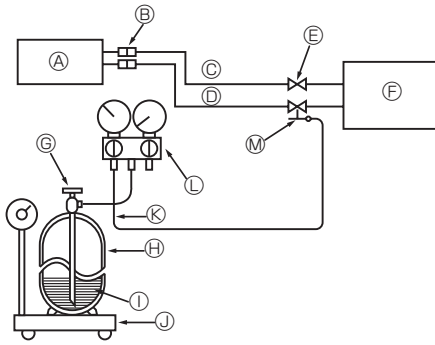

- |  |  |
|--|--|
| Ⓐ Indoor unit                              | ⓓ Refrigerant gas cylinder for R32 with siphon |
| Ⓑ Union                                    | ⓔ Refrigerant (liquid)                         |
| Ⓒ Liquid pipe                              | ⓕ Electronic scale for refrigerant charging    |
| Ⓓ Gas pipe                                 | ⓖ Charge hose (for R32)                        |
| ⓔ Stop valve                               | ⓗ Gauge manifold valve (for R32)               |
| Ⓕ Outdoor unit                             | ⓓ Service port                                 |
| Ⓖ Refrigerant gas cylinder operating valve |  |

Fig. 7-1

### 7.1. Gas charge (Fig. 7-1)

1. Connect gas cylinder to the service port of stop valve (3-way).
2. Execute air purge of the pipe (or hose) coming from refrigerant gas cylinder.
3. Replenish specified amount of refrigerant, while running the air conditioner for cooling.

**Note:**

In case of adding refrigerant, comply with the quantity specified for the refrigerating cycle.

**⚠ Caution:**

- Do not discharge the refrigerant into the atmosphere.  
Take care not to discharge refrigerant into the atmosphere during installation, reinstallation, or repairs to the refrigerant circuit.
- For additional charging, charge the refrigerant from liquid phase of the gas cylinder.

If the refrigerant is charged from the gas phase, composition change may occur in the refrigerant inside the cylinder and the outdoor unit. In this case, ability of the refrigerating cycle decreases or normal operation can be impossible. However, charging the liquid refrigerant all at once may cause the compressor to be locked. Thus, charge the refrigerant slowly.

To maintain the high pressure of the gas cylinder, warm the gas cylinder with warm water (under 40°C) during cold season. But never use naked fire or steam.

## 8. Pumping down

When relocating or disposing of the air conditioner, pump down the system following the procedure below so that no refrigerant is released into the atmosphere.

- ① Turn off the power supply (circuit breaker).
- ② Connect the gauge manifold valve to the service port of the stop valve on the gas pipe side of the outdoor unit.
- ③ Fully close the stop valve on the liquid pipe side of the outdoor unit.
- ④ Supply power (circuit breaker).
- ⑤ Perform the refrigerant collecting operation (cooling test run).
  - For the PAR-31MAA, select "Service" → "TestRun" from the main menu to start the test run, and then select the cooling mode.
  - For details or for other information about starting the test run when using remote controllers, refer to the installation manual for the indoor unit or the remote controller.
- ⑥ Fully close the stop valve on the gas pipe side of the outdoor unit when the pressure gauge shows 0.05 to 0 MPa [Gauge] (approx. 0.5 to 0 kgf/cm<sup>2</sup>) and quickly stop the air conditioner.
  - Push the "ON/OFF" button on the remote controller to stop the air conditioner.
  - \* Note that when the extension piping is very long with a large refrigerant amount, it may not be possible to perform a pump-down operation. In this case, use refrigerant recovery equipment to collect all of the refrigerant in the system.
- ⑦ Turn off the power supply (circuit breaker), remove the gauge manifold valve, and then disconnect the refrigerant pipes.

**⚠ Warning:**

When pumping down the refrigerant, stop the compressor before disconnecting the refrigerant pipes.

- If the refrigerant pipes are disconnected while the compressor is operating and the stop valve (ball valve) is open, the pressure in the refrigeration cycle could become extremely high if air is drawn in, causing the pipes to burst, personal injury, etc.



Please be sure to put the contact address/telephone number on this manual before handing it to the customer.

**MITSUBISHI ELECTRIC CORPORATION**

HEAD OFFICE: TOKYO BUILDING, 2-7-3, MARUNOUCHI, CHIYODA-KU, TOKYO 100-8310, JAPAN