



# **ZONE CONTROLLER**

**PAC-ZC40L-E**

**PAC-ZC80L-E**

**PAC-ZC40H-E**

**PAC-ZC80H-E**

---

## **INSTALLATION MANUAL**

**FOR INSTALLER**

For safe and correct use, read this manual thoroughly before installing the zone controller.

**English**

# Contents

1. Safety precautions.....	2	7. Before test run.....	22
2. Accessory.....	3	8. Initial setting.....	24
3. System.....	4	9. Troubleshooting.....	30
4. Zone Control Interface.....	7	10. Supplementary information.....	31
5. Zone Remote Controller.....	14	11. Specifications.....	32
6. Option.....	19		

Mitsubishi Electric is not responsible for the failure of locally supplied parts.

## 1. Safety precautions

▶ Before installing the zone controller, make sure you read all the “Safety precautions”.

**⚠ Warning:**  
Precautions that must be observed to prevent injuries or death.

**⚠ Caution:**  
Precautions that must be observed to prevent damages to the unit.

- ⚠ Warning:**
- The zone controller must not be installed by the user. Ask an installer or an authorized technician to install the zone controller. If the zone controller is installed improperly, electric shock, or fire may be caused.
  - For installation work, follow the instructions in the Installation Manual and use tools and pipe components specifically made for use with refrigerant specified in the outdoor unit installation manual.
  - The zone controller must be installed according to the instructions in order to minimize the risk of damages by earthquakes, typhoons, or strong winds. Improperly installed zone controller may fall down and cause damages or injuries.
  - The zone controller must be securely installed on a structure that can sustain its weight. If the zone controller is mounted on an unstable structure, it may fall down and cause damages or injuries.
  - All electric work must be performed by a qualified technician according to local regulations and the instructions given in this manual. If the zone controller is powered by dedicated power lines, correct voltage and circuit breakers must be used. Power lines with insufficient capacity or incorrect electrical work may result in electric shock or fire.

### 1.1. Before installation (Environment)

- ⚠ Caution:**
- Do not install the zone controller in outdoor location as it is designed for indoor installation only. Otherwise, electric shock or breakdown may be caused by water drop, wind or dust.
  - Do not use the zone controller in an unusual environment. If the zone controller is installed or exposed to steam, volatile oil (including machine oil), sulfuric gas, briny air, the internal parts can be damaged.
  - Do not install the zone controller where combustible gases may leak, be produced, flow, or accumulate. If combustible gas accumulates around the zone controller, it may cause fire or explosion.

### 1.2. Before installation or relocation

- ⚠ Caution:**
- Be fully careful when moving the zone controller. Do not hold the packaging bands. Wear protective gloves to unpack and to move it, in order to avoid your hands be injured by parts.

### 1.3. Before electric work

- ⚠ Caution:**
- Be sure to install a circuit breaker. If it is not installed, there may be a risk to get an electric shock.
  - For the power lines, use standard cables of sufficient capacity. Otherwise, it may cause a short circuit, overheating, or fire.
  - When installing the power lines, do not apply tension to the cables. The cables may be cut or overheated resulting in a fire.

### 1.4. Before starting the test run

- ⚠ Caution:**
- Turn on the main power switch of the outdoor unit more than 12 hours before starting operation. Starting operation immediately after turning on the power switch can severely damage the internal parts. Keep the main power switch turned on during the operation period.
  - Before starting operation, check that all protective parts are correctly installed. Make sure not to get injured by touching high voltage parts.

### 1.5. Damper motors

- ⚠ Warning:**
- The zone controller has signal outputs for damper motors however it can not isolate power to them in the event of overheating. All damper motors connected to the zone controller must comply with National regulation.

After installation, perform the test run to ensure normal operation. Then explain your customer the “Safety Precautions,” use, and maintenance of the unit based on the information in the Operation Manual provided by local application manufacturer. Both the Installation Manual and the Operation Manual must be given to the user. These manuals must always be kept by the actual users.

⚡ : Indicates a part which must be grounded.

**⚠ Warning:**  
Carefully read the labels attached to the unit.

- Only the specified cables can be used for wiring. Connections must be made securely without tension on the terminals. If cables are connected or installed improperly, it may result in overheating or fire.
- Terminal block cover panel of the zone controller must be firmly fixed. If the cover panel is mounted improperly, dust and moisture may enter the zone controller, and it may cause electric shock or fire.
- Make sure to use accessories authorized by Mitsubishi Electric and ask an installer or an authorized technician to install them. If accessories are improperly installed, it may cause electric shock, or fire.
- Do not remodel the zone controller. Consult an installer for repairs. If alterations or repairs are not performed correctly, it may cause electric shock or fire.
- The user should never attempt to repair the zone controller or transfer it to another location. If the zone controller is installed improperly, it may cause electric shock or fire. If the zone controller needs to be repaired or moved, ask an installer or an authorized technician.
- When installing sensors and parts, do not expose the terminals.

- When installing the zone controller in a hospital or in a building where communications equipment are installed, you may need to take measure to noise and electronic interference. Inverters, home appliances, high-frequency medical equipment, and radio communications equipment can cause the zone controller to malfunction or to breakdown. At the same time, the noise and electric interference from the zone controller may disturb the proper operation of medical equipment, and communications equipment.

- Be sure to safely dispose of the packaging materials. Packaging materials, such as nails and other metal or wooden parts may cause injuries.
- Do not wash the zone controller. You may receive an electric shock.

- Make sure to ground the zone controller. Do not connect the ground wire to gas or water pipes, lightning rods, or telephone grounding lines. If the zone controller is not properly grounded, there may be a risk to get an electric shock.
- Make sure to use circuit breakers (ground fault interrupter, isolating switch (+B fuse), and molded case circuit breaker) with the specified capacity. If the circuit breaker capacity is larger than the specified capacity, breakdown or fire may result.

- Do not touch any switch with wet hands. There may be a risk to get an electric shock.
- After stopping operation, make sure to wait at least 5 minutes before turning off the main power. Otherwise, it may cause breakdown.

- Zone controller must be powered off when changing or connecting damper motor.

## 2. Accessory

### 2.1. Check the parts (Fig. 2.1.1)

The zone controller should be supplied with the following parts.

	Parts Name	Qty
①	Zone control interface	1
②	Indoor unit - zone controller cable (2m)	1
③	Zone Remote controller	1

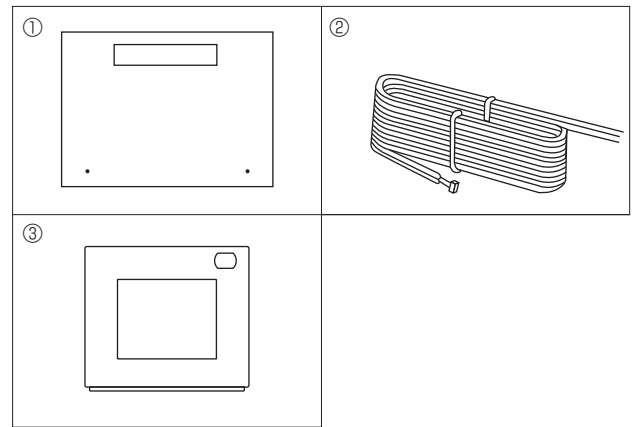

<Fig. 2.1.1>

### 3. System

Please refer to the following information to design your ducted air conditioning system with this zone controller.

#### 3.1. System outline

##### a) With common zone

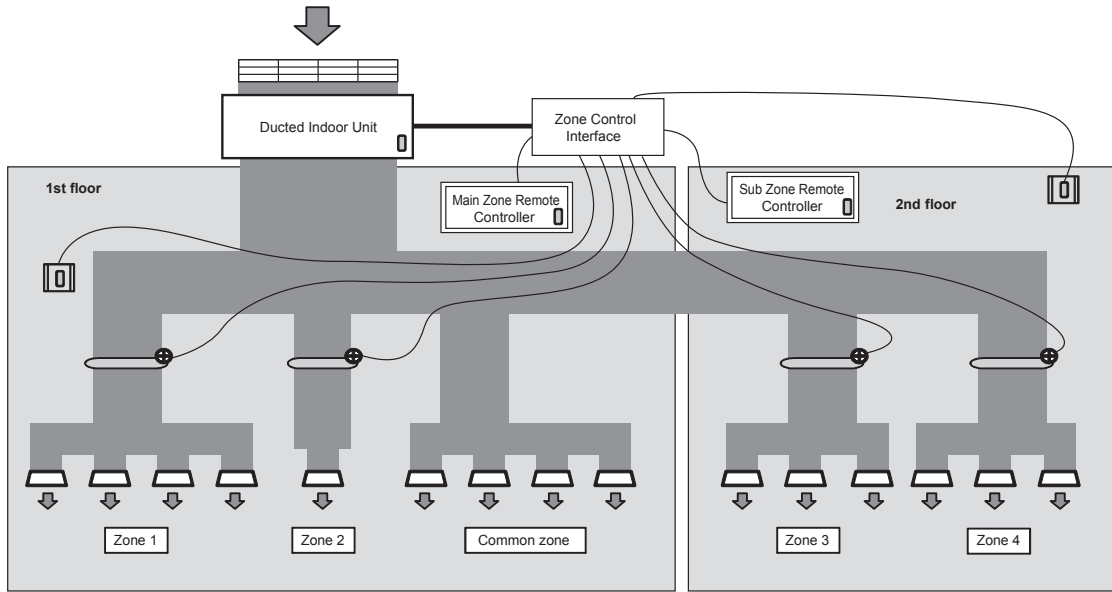

<Fig. 3.1>

Fig. 3.1 shows a system example, where common zone, 4 damper motors, 2 remote controllers and 2 optional temperature sensors are connected.

##### b) No common zone (Spill zone setting required)

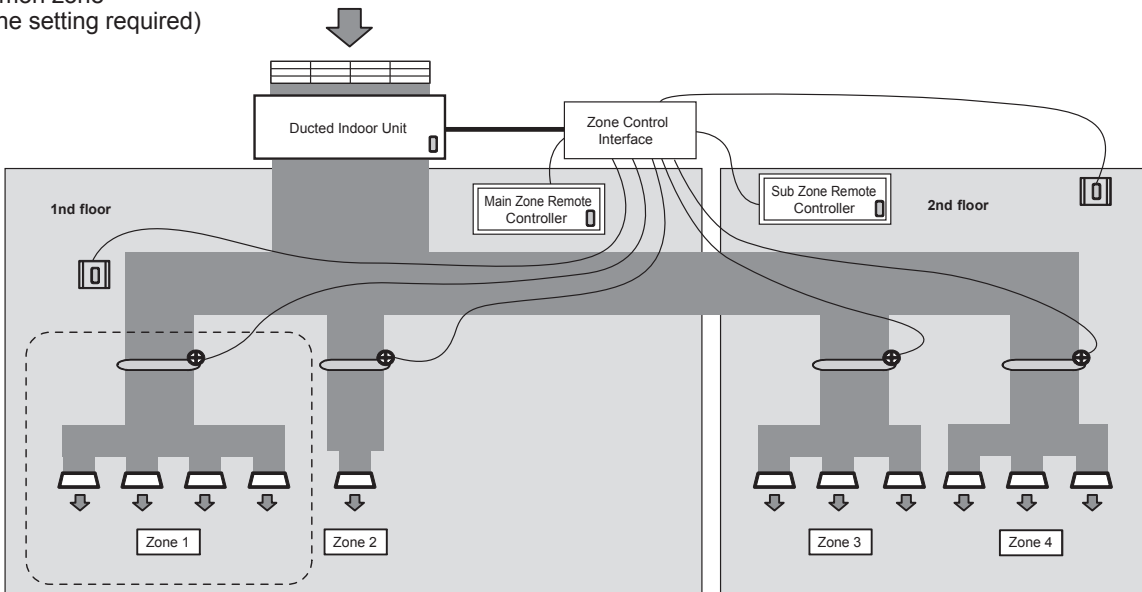

<Fig. 3.2>

Fig. 3.2 shows a system example, where no common zone, 4 damper motors, 2 remote controllers and 2 optional temperature sensors are connected.

This zone controller is designed for Mitsubishi Electric ducted indoor unit .  
Please contact your dealer to find out the model names of applicable units.

Symbol	Legend
	Air flow
	Duct
	Damper
	Damper motor
	Air outlet
	Air inlet
	Temperature sensor
	Optional temperature sensor
	Spill zone

### 3. System

#### 3.2. Wiring Diagram

a) 24V damper motor model

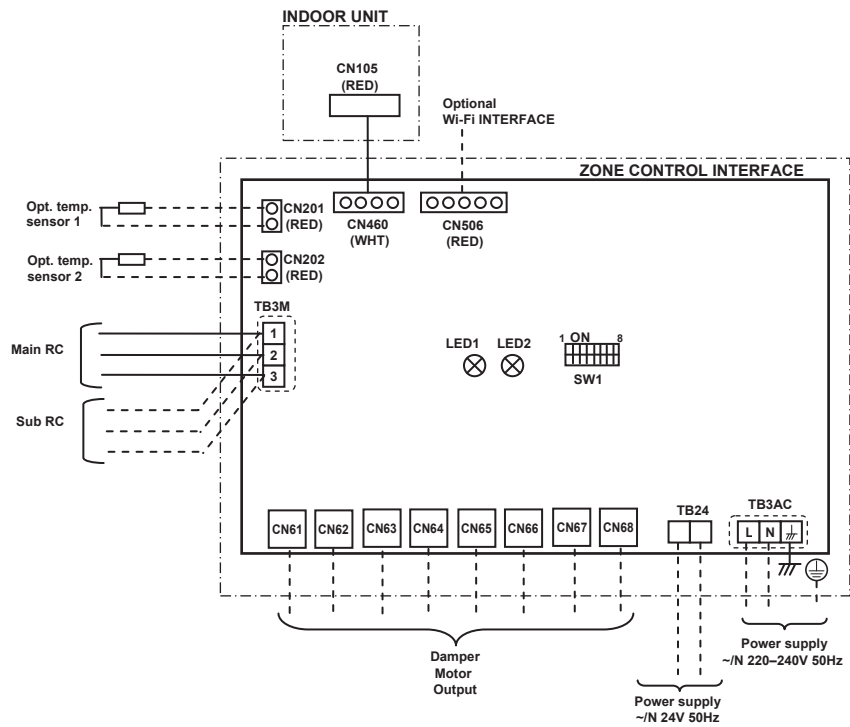

b) 240V damper motor model

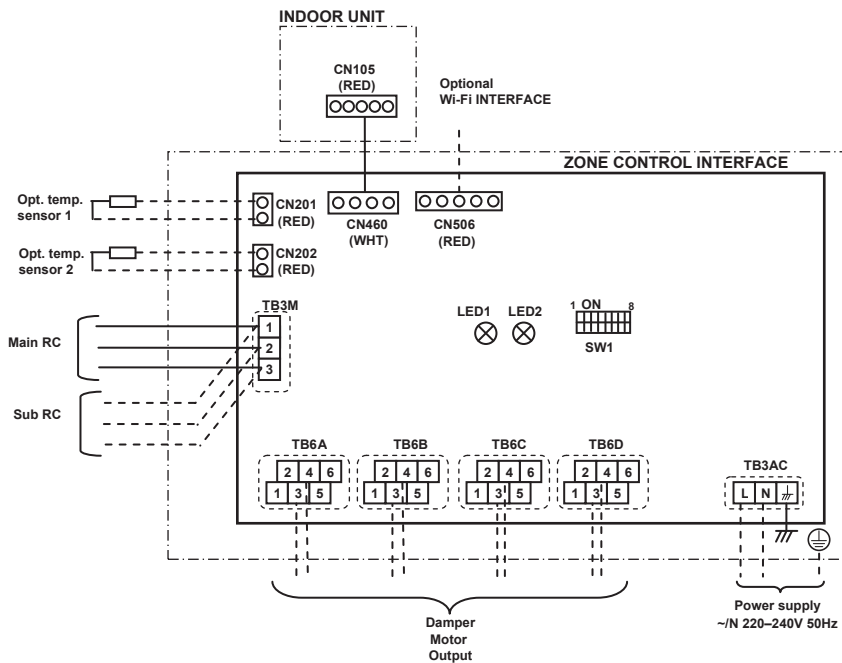

## 3. System

### 3.3. Component parts

Before making your system configuration, confirm the following information for the component parts.

Parts	Specification
Zone controller	Make sure to select the correct zone controller from the following 4 models. <ul style="list-style-type: none"><li>• Maximum 4 of 24V AC damper motor connecting type : PAC-ZC40L-E</li><li>• Maximum 8 of 24V AC damper motor connecting type : PAC-ZC80L-E</li><li>• Maximum 4 of 240V AC damper motor connecting type : PAC-ZC40H-E</li><li>• Maximum 8 of 240V AC damper motor connecting type : PAC-ZC80H-E</li></ul>
Zone remote controller	Maximum 2 remote controllers can be connected. 1 remote controller is included in the zone controller. If you would like to use 1 more remote controller, use the optional part.
Temperature sensor	For the air conditioner control, you can install 5 temperature sensors maximum as follows. <ul style="list-style-type: none"><li>• Intake air temperature sensor in the indoor unit.</li><li>• Temperature sensor in the main remote controller.</li><li>• Temperature sensor in the sub remote controller.</li><li>• Optional temperature sensor 1</li><li>• Optional temperature sensor 2</li></ul> They can be assigned to each of the zones.
Damper motor (LOCALLY SUPPLIED)	Only drive open, drive close damper motor can be connected. (Spring motor damper can not be used.) If you use 24V AC motors, ensure the transformer is adequately sized for the zone motors connected and is suitable for the installation conditions.

### 3.4. Duct design

Refer to the installation manual of the ducted indoor unit.

Due to auto fan function, all air outlets should have equal static pressure.

Common zone installation is recommended for preventing noisy outlets during air conditioner operation. However if you prefer no common zone system, you must set spill zones with the remote controller.

## 4. Zone Control Interface

### 4.1. Installation

#### 4.1.1 Choosing the zone controller installation location

- Do not install the zone controller in outdoor location as it is designed for indoor installation only. (The zone controller circuit board and casing are not waterproof.)
- Avoid locations where the zone controller is exposed to direct sunlight or other sources of heat.
- Select a location where easy wiring access to the power source is available.
- Avoid locations where combustible gases may leak, be produced, flow, or accumulate.
- Select a level location that can bear the weight and prevent vibration of the zone controller.
- Avoid locations where the zone controller is exposed to oil, steam, or sulfuric gas.
- Do not install in location that ambient temperature exceeds 60°C and relative humidity exceeds 80%.
- Do not install zone control interface on top of the indoor unit.

#### 4.1.2 Installing the zone controller

(Fig. 4.1.1, 4.1.2, 4.1.3, 4.1.4)

1. Remove 2 screws (A Screw) from zone controller and remove the cover. (See Fig. 4.1.1)
2. Install the 4 screws (locally supplied) in the 4 holes (C Hole).

**Note:** To prevent the unit from falling off the installation location, select the appropriate screws (locally supplied) and secure the base horizontally to the appropriate installation location. (See Fig. 4.1.2)

(A) Screw (B) Cover (C) Hole for installation

Weight	PAC-ZC40/80L-E: 2.5kg PAC-ZC40/80H-E: 2.7kg
Allowable ambient temperature	0 to 60°C
Allowable ambient humidity	80% RH or less

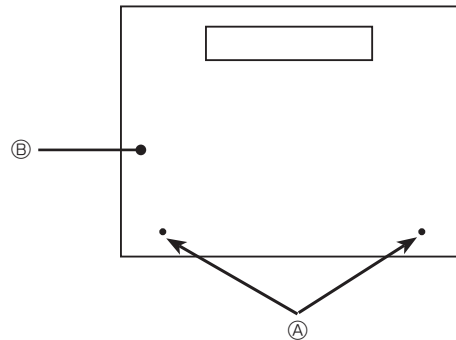

<Fig. 4.1.1>

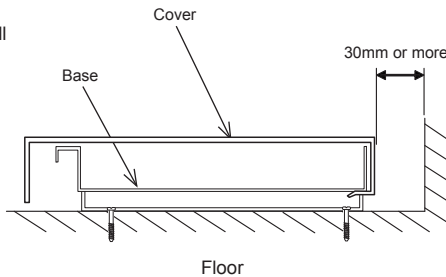
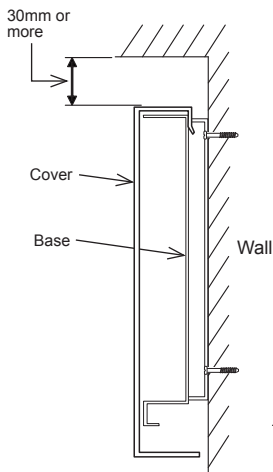

<Fig. 4.1.2>  
Service space

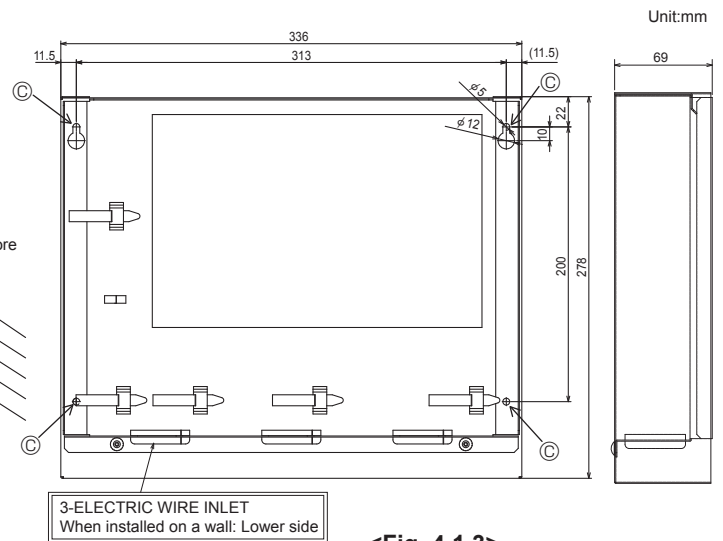

<Fig. 4.1.3>  
Service space

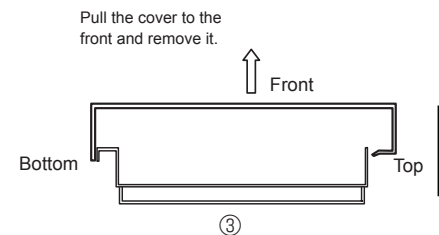
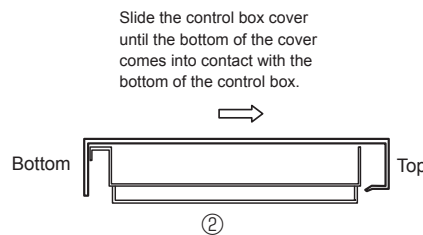
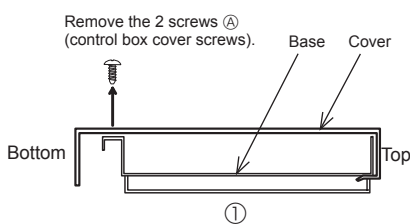

<Fig. 4.1.4>  
Service space

## 4. Zone Control Interface

### 4.2. Wirings

#### 4.2.1 24V damper motor model [PAC-ZC40L-E / PAC-ZC80L-E]

##### <Routing>

All electrical work shall be carried out by a suitably qualified technician. Failure to comply with this could lead to electrocution, fire, and death. All wiring must be conducted according to the national wiring regulations.

Connections should be made to the terminals indicated in the following figures depending on the voltage.

When terminating cables to terminal bed, please use electrical lugs.

- Notes:
1. Do not run the low voltage cables through a slot that the high voltage cables go through.
  2. Do not bundle power cables (240V) together with other cables.
  3. Bundle cables as Fig. 4.2.1 by using clamps.
  4. Remote controller cables, sensor cables, and other cables should be segregated by more than 50mm from each other until entry into the zone control interface. Also avoid cables running along metal surfaces.

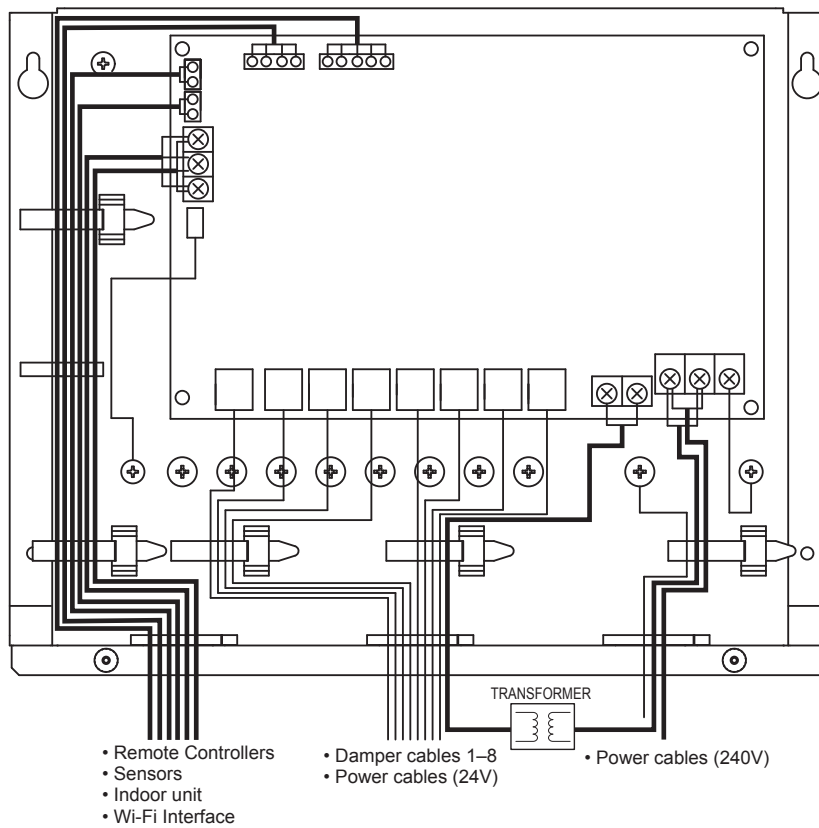

<Fig. 4.2.1>  
Wiring for the zone controller 24V damper model



## 4. Zone Control Interface

### <Connecting to indoor unit>

Use the accessory cable (② indoor unit-zone controller cable) for connecting CN460 on the zone control interface to CN105 on the indoor controller board.

#### Note:

Connect the cable to CN105 (RED) on the indoor control board A (I.B.A) for the indoor unit PEA-RP-GAA model.

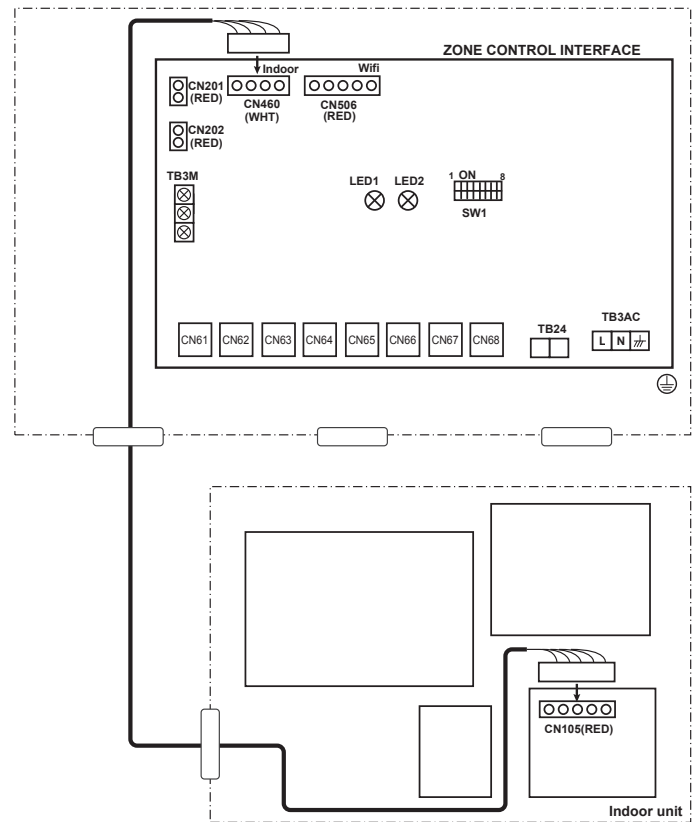

<Fig. 4.2.2>

### <Power supply>

#### a) Models with outdoor unit power supply

The models powered by outdoor unit can supply power to the zone control interface and the damper motor by connecting the 240V side of transformer to L and N on the TB3AC.

It can also be powered via an independent power source.

When the power source cables exceed the wiring length indicated in the following table, the power source wire of the indoor unit and the zone controller should wire separately.

Maximum wiring length

Wiring size	Outdoor unit - Indoor unit wiring length
1.5mm <sup>2</sup>	Max 30m
2.5mm <sup>2</sup>	Max 50m

#### b) Models with separate indoor/ outdoor unit power supplies

The models with separate indoor/ outdoor unit power supplies can supply power to the zone control interface and the damper motor by connecting the 24V side of transformer to L and N on the TB3AC.

It can also be powered an independent power source.

#### Notes:

1. Wiring size must comply with the applicable local and national codes.
2. Remote controller/ Indoor unit connecting cords shall not be lighter than polychloroprene sheathed flexible cord. (Design 60245 IEC 57)
3. Install an earth longer than other cables.

Wiring specification

Wiring	Zone control interface CN460 - Indoor unit CN105	*1
Wiring No. xsize(mm <sup>2</sup> )	Zone control interface TB3AC L,N - Indoor unit	2×Min. 1.0
	Zone control interface unit earth	1×Min. 1.0
Circuit rating	Zone control interface TB3AC L,N - Indoor unit	220-240V AC
	Transformer - TB24	24V AC *2

\*1 Use the accessory cable (② indoor unit-zone controller cable).

\*2 The 24V AC is used only for the model which is adaptable to 24V damper motor.

### Zone controller powered via indoor unit

Connecting to the model powered by outdoor unit

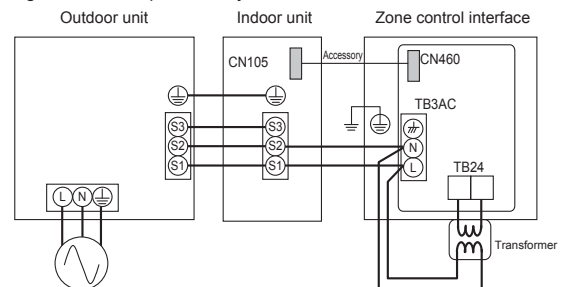

<Fig. 4.2.3>

Power supply wiring for 24V damper motor model

Connecting to the model with separate indoor/ outdoor unit power supplies

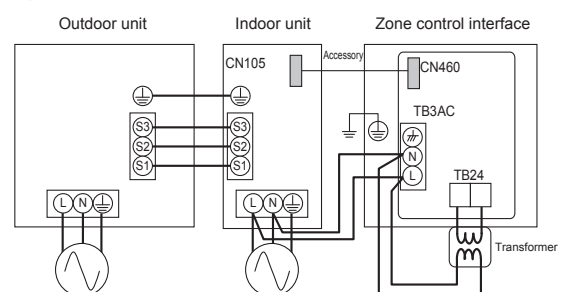

<Fig. 4.2.4>

Power supply wiring for 24V damper motor model

## 4. Zone Control Interface

### <Damper motors>

Connect the damper motor cable to CN61 to CN68.  
The damper motor is powered via TB24.

Do not connect the 240V AC cable to TB24.

Refer to the following table to connect the cable to the correct zone.  
Use the cable with proper pin assignment.

#### External outputs

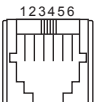
Name	Terminal block	Item	Connector type
Zone1	CN61	Damper moter output1	 PIN1,2:OPEN, PIN3,4:COM, PIN5,6:CLOSE
Zone2	CN62	Damper moter output2	
Zone3	CN63	Damper moter output3	
Zone4	CN64	Damper moter output4	
Zone5	CN65	Damper moter output5	
Zone6	CN66	Damper moter output6	
Zone7	CN67	Damper moter output7	
Zone8	CN68	Damper moter output8	
AC24V	TB24	24V AC damper source supply	no polarity

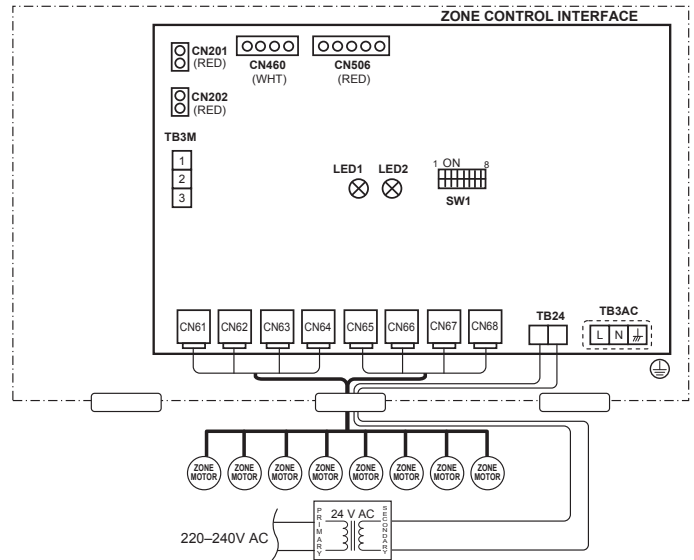

<Fig. 4.2.5>

Ensure that the damper motor and the damper motor cable to be used meet the following specification.

#### Locally supplied parts

		Specification
Damper motor	Voltage	24V AC
	Frequency	50Hz/60Hz
	Maximum Operation Current (per damper)	360mA or less
	Maximum Electric Power (per damper)	7VA or less
Damper motor cable	Wire diameter (mm <sup>2</sup> )	0.48mm <sup>2</sup> or more
	Maximum wiring length	30m or less
	Type	RJ12 6-pole, 6-core
Transformer *1	Input Voltage	240V AC
	Output Voltage	24V AC

\*1 The size or power supply method shall be selected properly depending on the type of the damper motor and the damper motor cable to be used.

**⚠ Caution: Wiring size must comply with the applicable local and national codes.**

When connecting damper motors, ensure to connect them sequentially starting from zone 1.

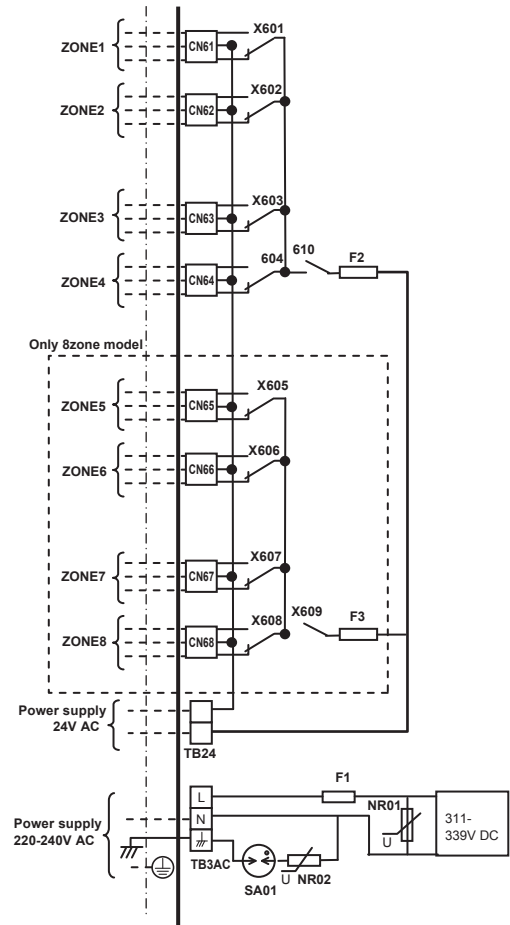

<Fig. 4.2.6>

## 4. Zone Control Interface

### 4.2.2 240V damper motor model [PAC-ZC40H-E / PAC-ZC80H-E]

#### <Routing>

All electrical work shall be carried out by a suitably qualified technician. Failure to comply with this could lead to electrocution, fire, and death. All wiring must be conducted according to the national wiring regulations.

Connections should be made to the terminals indicated in the following figures depending on the voltage.

**When terminating cables to terminal bed, please use electrical lugs.**

#### Notes:

1. Do not run the low voltage cables through a slot that the high voltage cables go through.
2. Do not bundle power cables and damper cables together with other cables.
3. Bundle cables as Fig. 4.2.7 by using clamps.
4. Remote controller cables, sensor cables, and other cables should be segregated by more than 50mm from each other until entry into the zone control interface. Also avoid cables running along metal surfaces.

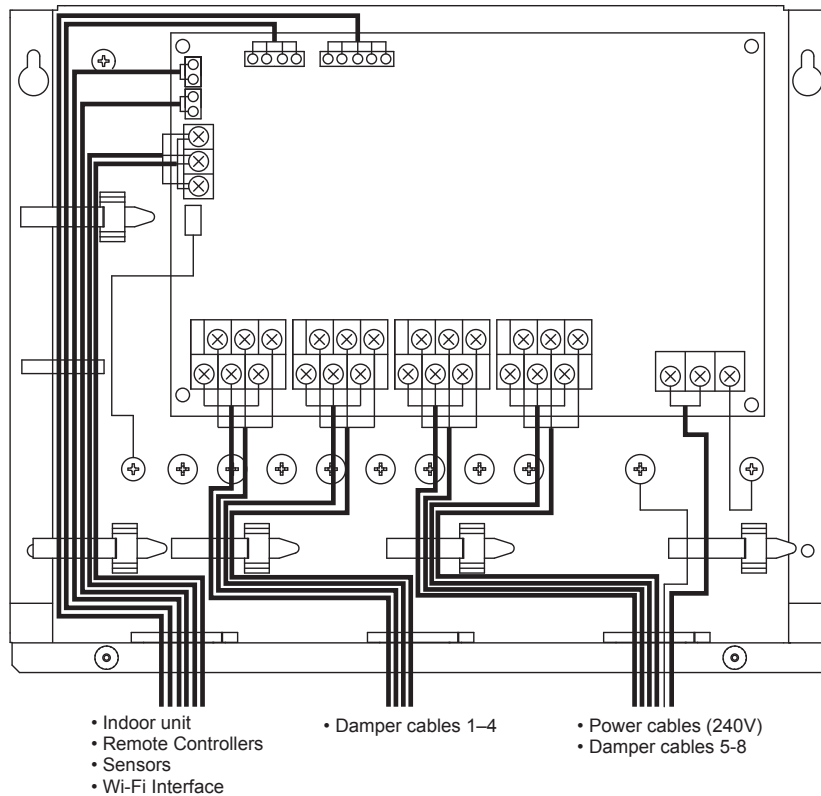

**<Fig. 4.2.7 >**  
Wiring for the zone controller 240V damper model

## 4. Zone Control Interface

### <Indoor unit connection>

Use the accessory cable (② indoor unit-zone controller cable) for connecting CN460 on the zone control interface to CN105 on the indoor controller board.

#### Note:

Connect the cable to CN105 (RED) on the indoor control board A (I.B.A) for the indoor unit PEA-RP-GAA model.

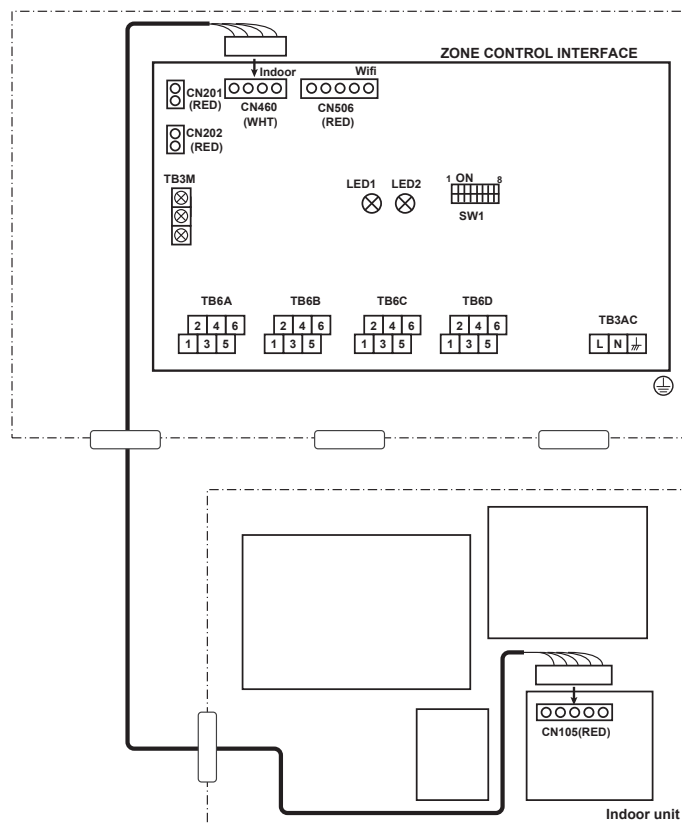

<Fig. 4.2.8>

### <Power supply >

#### a) Models with outdoor unit power supply

The models powered by outdoor unit can supply power to the zone control interface and the damper motor via S1 and S2 on the indoor unit. It can also be powered via an independent power source.

When the power source cables exceed the wiring length indicated in the following table, the power source wire of the indoor unit and the zone controller should wire separately.

Maximum wiring length

Wiring size	Outdoor unit - Indoor unit wiring length
1.5mm <sup>2</sup>	Max 30m
2.5mm <sup>2</sup>	Max 50m

#### b) Models with separate indoor/ outdoor unit power supplies

For the models with separate indoor/ outdoor unit power supplies, a power supply source for the zone controller and the damper motor can be connected to the power terminal block on indoor controller board. It can also be powered via an independent power source.

#### Notes:

1. Wiring size must comply with the applicable local and national codes.
2. Remote controller/ Indoor unit connecting cords shall not be lighter than polychloroprene sheathed flexible cord. (Design 60245 IEC 57)
3. Install an earth longer than other cables.

Wiring	Zone control interface CN460 - Indoor unit CN105	*1
Wiring No. xsize(mm <sup>2</sup> )	Zone control interface TB3AC L,N - Indoor unit	2×Min. 1.0
	Zone control interface unit earth	1×Min. 1.0
Circuit rating	Zone control interface TB3AC L,N - Indoor unit	220-240V AC

\*1 Use the accessory cable (② indoor unit-zone controller cable).

### Zone controller powered via indoor unit

Connecting to the model powered by outdoor unit

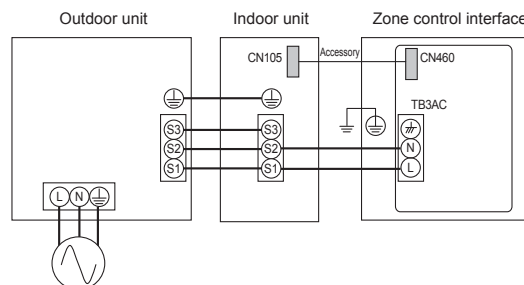

<Fig. 4.2.9>

Power supply wiring for 240V damper motor model

Connecting to the model with separate indoor/ outdoor unit power supplies

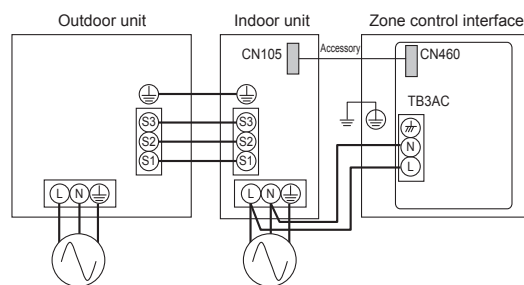

<Fig. 4.2.10>

Power supply wiring for 240V damper motor model

## 4. Zone Control Interface

### <Damper motors>

Connect the damper motor cable to TB6A, TB6B, TB6C and TB6D.  
The damper motor is powered via TB3AC.

Refer to the following table to connect the damper motor to the correct terminal block.

#### External outputs

Name	Terminal block	Item	Connector type
Zone1	TB6A 1,3,5	Damper motor output1	1:OPEN, 3:COM, 5:CLOSE 2:OPEN, 4:COM, 6:CLOSE
Zone2	TB6A 2,4,6	Damper motor output2	
Zone3	TB6B 1,3,5	Damper motor output3	
Zone4	TB6B 2,4,6	Damper motor output4	
Zone5	TB6C 1,3,5	Damper motor output5	
Zone6	TB6C 2,4,6	Damper motor output6	
Zone7	TB6D 1,3,5	Damper motor output7	
Zone8	TB6D 2,4,6	Damper motor output8	

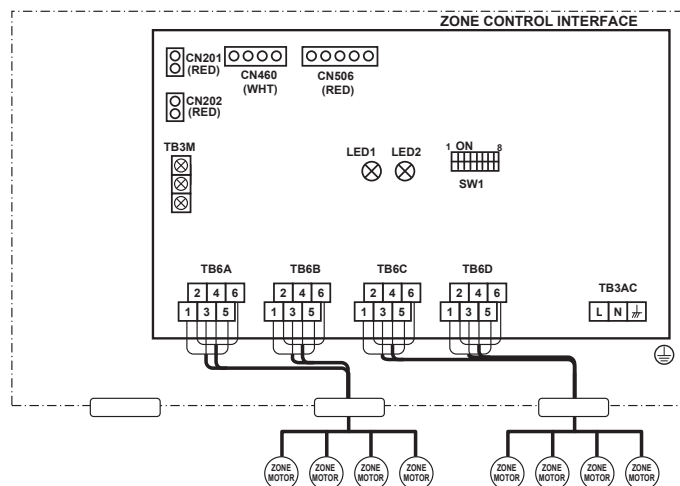

<Fig. 4.2.11>

Ensure that the damper motor and the damper motor cable to be used meet the following specification.

#### Locally supplied parts

		Specification
Damper motor	Voltage	240V AC
	Frequency	50Hz/60Hz
	Maximum Operation Current (per damper)	70mA or less
	Maximum Electric Power (per damper)	12VA or less
Damper motor cable	Wire diameter (mm <sup>2</sup> )	0.75–1.5mm <sup>2</sup>
	Maximum wiring length	30m or less
	Type	Type 60227 IEC52 or 53

When connecting damper motors, ensure to connect them sequentially starting from zone 1.

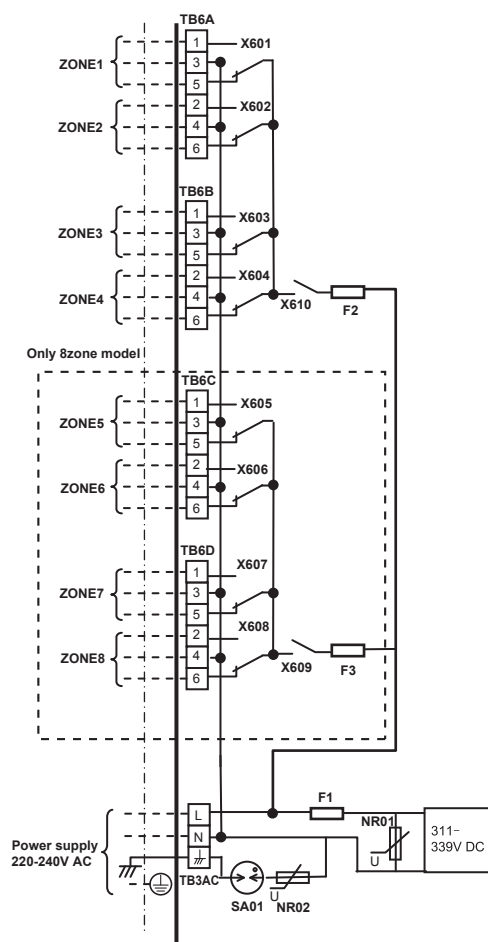

<Fig. 4.2.12>

## 5. Zone Remote Controller

### 5.1. Main zone remote controller

#### 5.1.1. Installing the zone remote controller

This remote controller is for the wall installation. It can be installed either on a mounting block or directly on the wall. When performing direct wall installation, cables can be thread through either back or top of the remote controller.

(1) Selecting an installation site

Install the remote controller on the site where the following conditions are met.

(a) A flat surface

(b) A place where the remote controller can measure the accurate room temperature

Sensors to monitor the room temperature on the indoor unit and on the remote controller.

- To monitor the accurate room temperature, install the remote controller away from direct sunlight, heat sources, and the supply air outlet of the air conditioner.
- Install the remote controller in a location that allows the sensor to measure the representative room temperature.
- Install the remote controller where no wires are routed around the temperature sensor on the controller or where no obstacles block the air inlet, otherwise the sensor cannot measure accurate room temperature.
- Do not install the controller where it is exposed to high concentration of acid, alkaline, or volatile organic compounds.

(c) Install the remote controller where occupancy and brightness can be properly detected.

The remote controller has an occupancy sensor and a brightness sensor.

Each sensor has a sensor-detection area.

- Install the remote controller where the coverage area covers the appropriate area in the room.

The maximum distance the sensor can detect occupancy is approximately 10 m (32 ft).

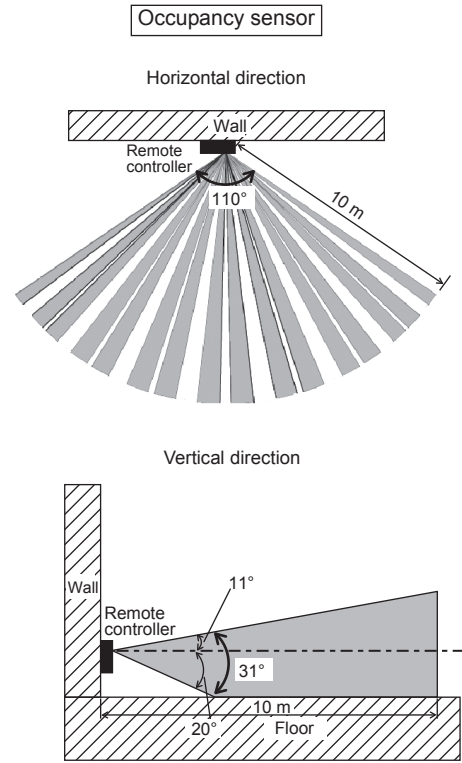

<Fig. 5.1.1>

■ : Detection area

**Note:** As an inherent characteristic of the occupancy sensor, it is more sensitive to movements across the area indicated by ■ than to movements straight toward the sensor.

## 5. Zone Remote Controller

Occupancy sensor detects occupancy based on the temperature difference between the occupant and its surroundings.

The occupancy sensor is designed to detect the changes in the amount of infrared light emitted from an object in the detection area, including human bodies.

The occupancy sensor will not detect occupancy if no movements exist.

The sensor also becomes less sensitive to occupancy when the temperature difference between the occupant and its surroundings is small.

Select the installation location carefully to avoid false detection.

### Factors that contribute to false detection by the occupancy sensor

- Direct sunlight to the remote controller
- Supply air directed straight toward the remote controller
- Fireplace in the detection zone
- Portable heater (e.g., oscillating electric heater) in the detection area
- Excessive vibrations or large impact inflicted on the remote controller
- Strong electrical noise
- Movements of small animals, such as cats and dogs

### Handling precautions

- Keep the lens scratch-free.
- Do not place adhesive tape or labels over the lens.
- Use a soft cloth to clean the lens.

### Important

Do not use solderless terminals to connect cables to the terminal block. Solderless terminals may come in contact with the circuit board and cause malfunctions or damage the controller cover.

To avoid deformation and malfunction, do not install the remote controller in direct sunlight, where the ambient temperature may rise above 40°C (104°F) or drop below 0°C (32°F), or where the relative humidity may rise above 90% or drops below 20%.

To reduce the risk of malfunctions, do not install the controller in a place where water or oil may come into contact with the controller, or in a condensing or corrosive environments.

Do not install the remote controller directly onto electrically conductive objects such as metal plate that has not been painted.

To use the Energy Saving Assist function in a system with both main and sub remote controllers, activate the function only on the remote controller whose coverage area is the largest.

### Important

Use caution when handling circuit boards to prevent damage from static electricity. Although the circuit board is covered with an insulation sheet, part of the circuit board is exposed. Use extra caution not to let your fingers come in contact with the circuit board.

The remote controller can be installed either on a mounting block or directly on the wall. Perform the installation properly according to the method.

#### ① Drill a hole in the wall.

- Installation using a mounting block
  - Drill a hole in the wall, and install the mounting block on the wall.
  - Connect the mounting block to the conduit tube.
- Direct wall installation
  - Drill a hole in the wall, and thread the cable through it.

**Note: No cable access hole is required when running the remote controller cable along the wall.**

#### ② Seal the cable access hole with putty.

- Installation using a mounting block
  - Seal the cable access hole at the connection of mounting block and conduit tube with putty.

To reduce the risk of electric shock, malfunctions, or fire, seal the gap between the cables and cable access holes with putty.

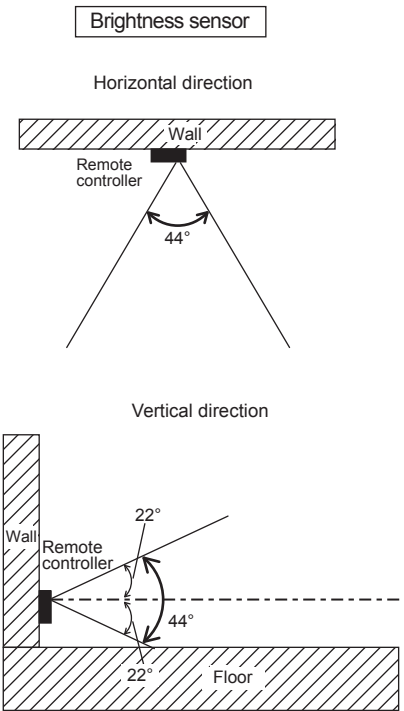

<Fig. 5.1.2>

### Required space around the remote controller

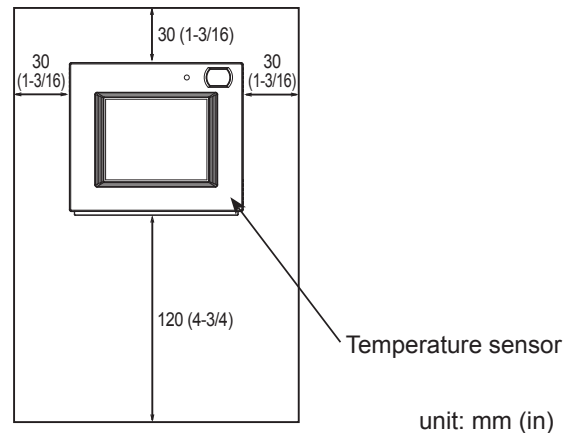

<Fig. 5.1.3>

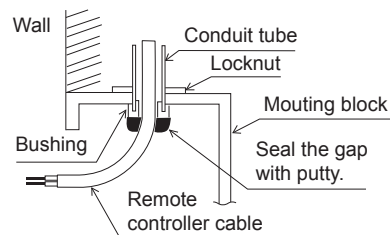

<Fig. 5.1.4>

## 5. Zone Remote Controller

- ③ Prepare the bottom case of the remote controller.  
Take the following procedure only when performing direct wall installation and running the remote controller cable along the wall.

- Cut out the thin-wall part on the cover (indicated with the shaded area in the right figure) with a knife or a nipper.

**Note:**

Make sure that the hole edges are smooth and will not damage the wires.

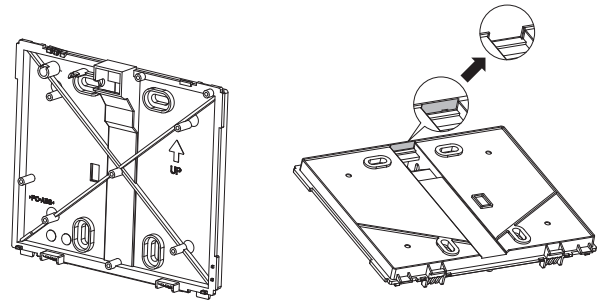

Bottom case

<Fig. 5.1.5>

<Fig. 5.1.6>

- ④ Install the bottom case.
- Remove the sheath as shown in the figure at right, and route the remote controller cable behind the bottom case.  
Install the bottom case.
  - Installation using a mounting block
    - Secure at least two corners of the switch box with screws.
  - Direct wall installation
    - Secure at least two corners of the remote controller with screws.
    - Be sure to secure top-left and bottom-right corners of the remote controller (viewed from the front) to prevent it from lifting. (Use wall anchor etc.)

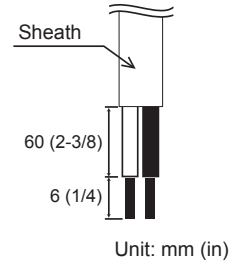

Unit: mm (in)

<Fig. 5.1.7>

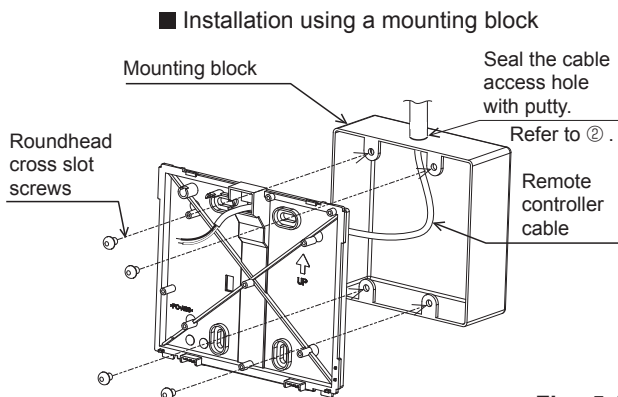

<Fig. 5.1.8>

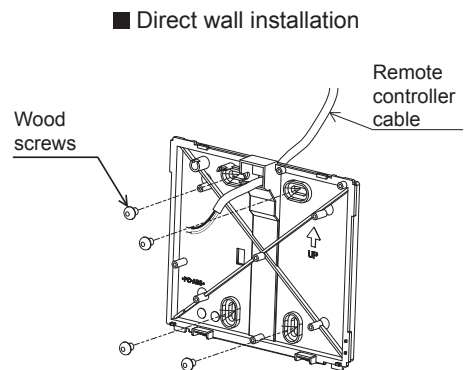

**Important**

To avoid damage to the controller, do not overtighten the screws.

To avoid damage to the controller, do not make holes on the controller cover.

- ⑤ Install the top case on the bottom case.  
Two mounting tabs are at the top of the top case.  
Hook those two tabs onto the bottom case, and click the top case into place.  
Check that the case is securely installed and can not be lifted.

The controller is shipped with the front cover mounted to the top case.  
Remove the front cover from the top case before installing the top case on the wall.  
Refer to "① Uninstalling the front cover" on page 18.

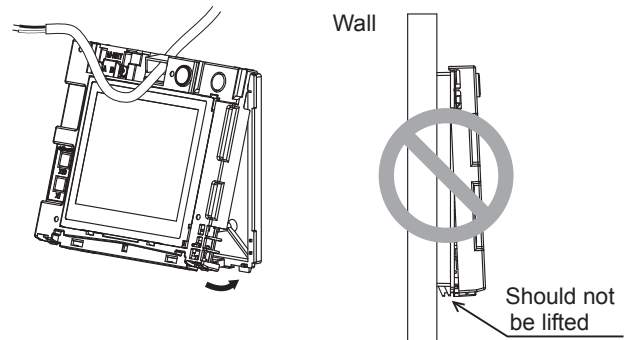

<Fig. 5.1.9>



## 5. Zone Remote Controller

- ⑥ **Connect the remote controller cable to the terminal block on the top case.**  
Connect the remote controller cable to the terminal block.

To reduce the risk of electric shock, shorting, or malfunctions, keep wire pieces and sheath shavings out of the terminal block.

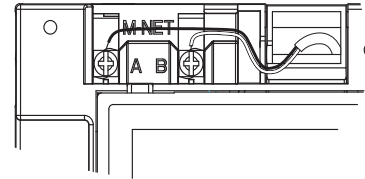
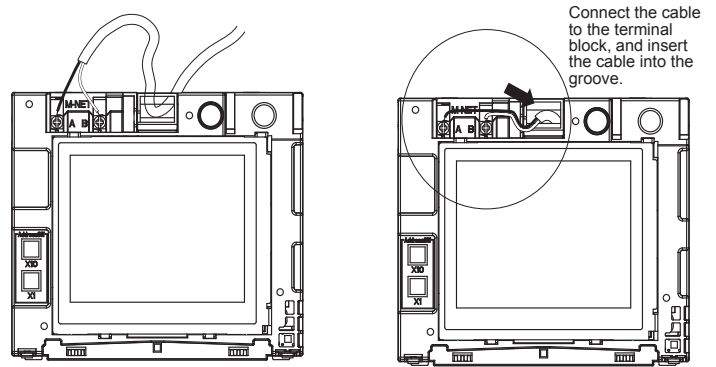

<Fig. 5.1.10>

### Important

Do not use solderless terminals to connect cables to the terminal block. Solderless terminals may come in contact with the circuit board and cause malfunctions or damage the controller cover.

Hold the cables in place with clamps to prevent undue force from being applied to the terminal block and causing cable breakage.

Take the following procedure only when performing direct wall installation and drilling a hole in the wall.

- Seal the hole through which the cable is threaded with putty.

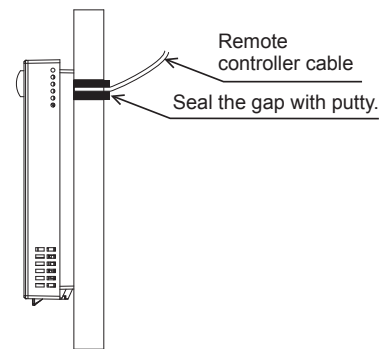

<Fig. 5.1.11>

- ⑦ **Set the M-NET addresses.**

	Address range	Address setting method
Main remote controller	101	Not necessary since it is set to 101 as initial setting.

### Note:

**M-NET address can be changed with or without the power being applied to the controller.**

The screen will jump to the [Start-up] screen.

Zone settings will be deleted, but the rest of the information will be retained.

### Important

To set the address, turn the rotary switch with a precision slotted screwdriver [(-), 2.0mm (1/16 in) (W)] to a torque of less than 19.6 N to avoid the damage to the rotary switches.

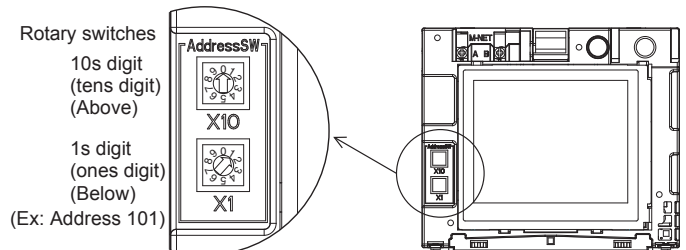

<Fig. 5.1.12>

## 5. Zone Remote Controller

### ⑧ Install the front cover on the top case.

Two mounting tabs are at the top of the front cover.  
Hook those two tabs onto the top case, and click the front cover into place.  
Check that the case is securely installed and not lifted.

#### Important

When attaching the front cover to the top case, push it until it they click into place.  
If it is not properly locked into place, it may fall, causing personal injury, controller damage, or malfunctions.

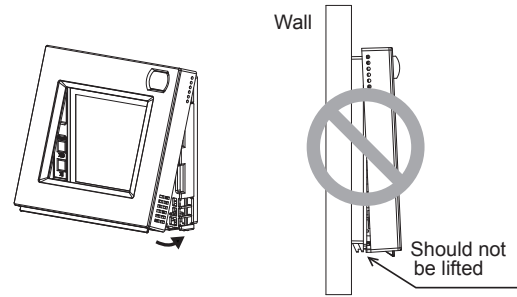

<Fig. 5.1.13>

### ■ Direct wall installation (when running the cable along the wall)

- Thread the cable through the access hole at the top of the remote controller.
- Seal the cut-out part of the cover with putty.
- Use a cable cover.

Installation is complete.

Follow the instructions below when uninstalling them.

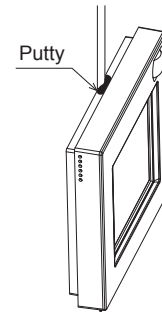

<Fig. 5.1.14>

### • Uninstalling the front cover and top case

#### ① Uninstalling the front cover

Insert a flat-tip screwdriver (with a blade width of 5.5mm (7/32 in) or less) into either of the two latches at the bottom of the remote controller as shown in the figure at right.

Lightly push the tip of the flat-head screwdriver in the direction of the arrow in the figure to remove the front cover.

#### ② Uninstalling the top case

Insert a flat-tip screwdriver (with a blade width of 5.5mm (7/32 in) or less) into either of the two latches at the front of the remote controller as shown in the figure at right.

Push the tip of the flat-head screwdriver in the direction of the arrow in the figure to remove the top case.

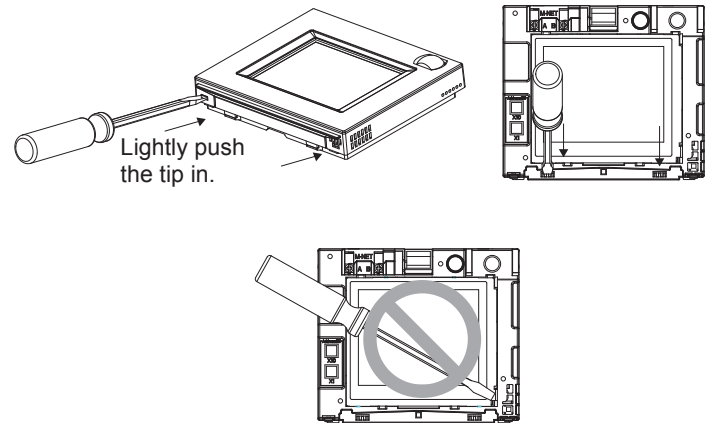

<Fig. 5.1.15>

#### Important

Use a flat-head screwdriver with a blade width of 4-5.5mm (5/32-7/32 in).  
The use of a screwdriver with a narrower or wider blade tip may damage the controller casing.

To prevent damage to the control board, do not insert the driver into the slot strongly.

To prevent damage to the controller casing, do not force the driver to turn with its tip inserted in the slot.

### 5.1.2. Connecting the zone remote controller cable to the zone control interface

Maximum 2 remote controllers can be connected to TB3M. Connect the remote controller cable to M1, M2 on the terminal block (TB3M) <Fig. 5.1.16>. Connect the part of shield wiring of remote controller cable to S on the terminal when using 2-core shielded cable.

	Wiring (under 10m)	Wiring (10-200m)
Wiring wire	2×0.3mm <sup>2</sup> (standard AWG22) *1	CVVS1.25mm <sup>2</sup> (standard AWG 16) or CPEVSφ1.2mm (standard AWG 16) or equivalent *1
Wiring type	2-core sheathed cable	2-core shielded cable
Circuit rating	24-30V DC	

\*1 For remote controllers, use a cable with supplementary insulation; double coating or minimum thickness coating of 1mm.

#### Notes:

Wiring for remote controller cable shall be (5 cm or more) apart from power source wiring so that it is not influenced by electric noise from power source wiring. (Do not insert remote controller cable and power source wiring in the same conduit.) (Refer to Fig. 4.2.1 and Fig. 4.2.7)

When wiring to TB3M, use the ring type lugs and insulate them from the cables of adjoining terminals.

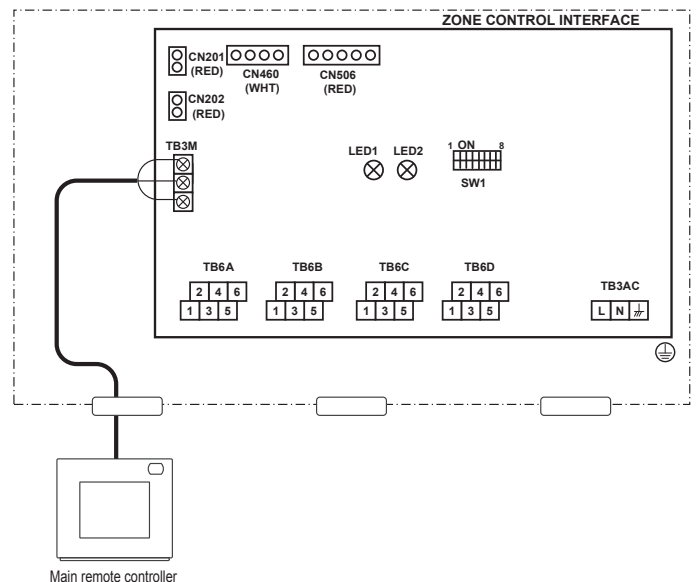

<Fig. 5.1.16>

## 6. Option

### 6.1. Sub zone remote controller

#### 6.1.1. Connect the zone remote controller cable to the zone control interface

Maximum 2 remote controllers can be connected to TB3M. Connect the remote controller cable to M1, M2 on the terminal block (TB3M) <Fig. 6.1.1>. Connect the part of shield wiring of remote controller cable to S on the terminal when using 2-core shielded cable.

	Wiring (under 10m)	Wiring (10–200m)
Wiring wire	2×0.3mm <sup>2</sup> (standard AWG22) *1	CVVS1.25mm <sup>2</sup> (standard AWG 16) or CPEVSφ1.2mm (standard AWG 16) or equivalent *1
Wiring type	2-core sheathed cable	2-core shielded cable
Circuit rating	24–30V DC	

\*1 For remote controllers, use a cable with supplementary insulation; double coating or minimum thickness coating of 1mm.

#### Notes:

Wiring for remote controller cable shall be 5 cm or more apart from power source wiring so that it is not influenced by electric noise from power source wiring. (Do not insert remote controller cable and power source wiring in the same conduit.) (Refer to Fig. 4.2.1 and Fig. 4.2.7)

When wiring to TB3M, use the ring type lugs and insulate them from the cables of adjoining terminals.

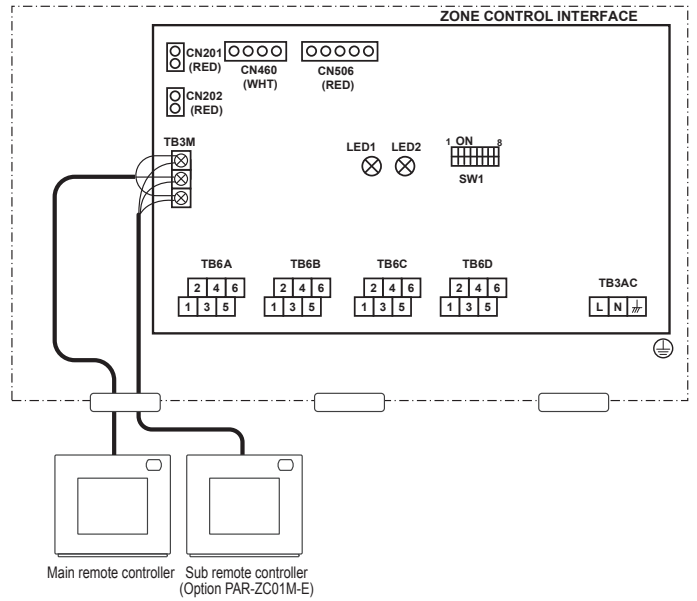

<Fig. 6.1.1>

#### Set the M-NET addresses.

	Address range	Address setting method
Sub remote controller	151	Set to 151.

#### Note:

M-NET address can be changed with or without the power being applied to the controller.

The screen will jump to the [Start-up] screen.

Zone settings will be deleted, but the rest of the information will be retained.

#### Important

To set the address, turn the rotary switch with a precision slotted screwdriver [(-), 2.0mm (1/16 in) (W)] to a torque of less than 19.6 N to avoid the damage to the rotary switches.

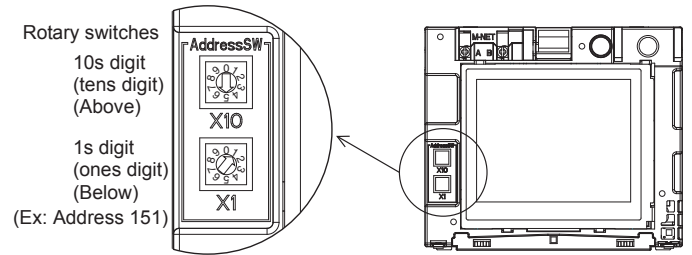

<Fig. 6.1.2>

## 6. Option

### 6.2. Temperature sensor

Maximum 2 optional temperature sensor(s) are available for the zone controller. Use only PAC-SE41TS-E.

#### 6.2.1. Connecting Opt. temp. sensor (TH1, TH2)

- Connect the TH1 cable to the CN201
- Connect the TH2 cable to the CN202

When the TH1, TH2 cables are too long, connect to TH1, TH2 connector (CN201, CN202) after cutting the sensor side of cable to the appropriate length, or bundle the excess cable outside the zone control interface. Use an accessory convert cable of the optional temperature sensor for connecting CN201, CN202.

#### ⚠ Caution:

**Do not route the temperature sensor cables together with power cables. The sensor part of the temperature sensor should be installed where user can not access. (It should be separated, by supplementary insulation, from areas the user can access.)**

#### 6.2.2. Installation

- ① Select a place where the remote sensor will detect an average temperature of the room, and where the sensor will not be subject to direct sunlight, heat sources, or in the airflow path from an outlet, etc.
- ② Install the sensor within the length of the cable provided (12 m).

**The cable cannot be extended. If extended, it may cause misoperation due to noise.**

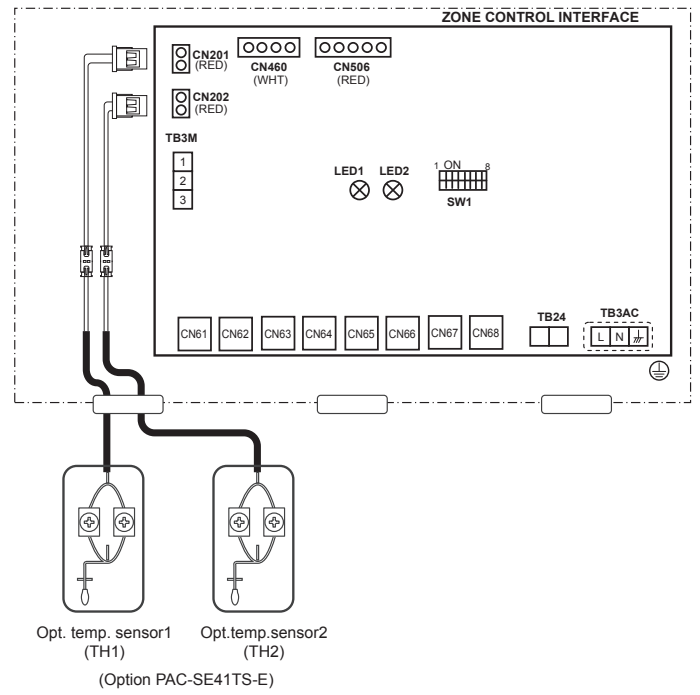

<Fig. 6.2.1>

## 6. Option

### 6.3. Connecting Wi-Fi INTERFACE

When connecting Wi-Fi Interface, connect it to CN506 on the zone controller circuit board.

Bundle the Wi-Fi cable together with the cable for remote controller and indoor unit-zone controller cable using a band.

Regarding the initial setting of Wi-Fi INTERFACE, refer to the Wi-Fi INTERFACE Installation Manual.

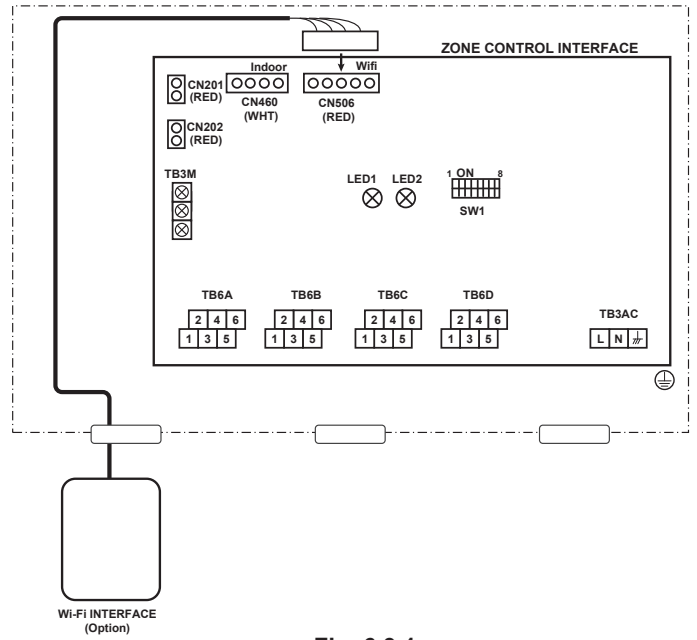

<Fig. 6.3.1>

## 7. Before test run

Before turning on the remote controller, first make sure that the remote controller, zone control interface, indoor unit, and outdoor unit have been installed properly according to the instructions detailed in the respective manuals. Then, turn on the zone control interface and the air conditioner units.

### 7.1. Wiring check

#### (1) Communication check

Check that the LED on zone controller interface

Turn on the zone control interface and the air conditioner units. After 5 minutes, please confirm that LED of the interface becomes in following state.

●	ON
○	OFF
☼	Flashing (interval)

SW1

1	2	3	4	5	6	7	8
ON	OFF	OFF	OFF	OFF	OFF	OFF	OFF
OFF	OFF	OFF	OFF	OFF	OFF	OFF	OFF

DIP SW setting

Item	Display	Content
LED1 (Green)	☼ (1s)	The communication between Indoor unit and Zone control interface is normal.
	○	Zone control interface cannot communicate with Indoor unit. Please confirm the followings. <ul style="list-style-type: none"> <li>• The cable is connected to CN460 of Zone control interface.</li> <li>• The cable is connected to CN105 of Indoor unit.</li> </ul>
LED2 (Orange)	☼ (within 60s)	The communication between Remote controller and Zone control interface is normal.
	○	Zone control interface cannot communicate with Remote controller. Please confirm the followings. <ul style="list-style-type: none"> <li>• The cable is connected to TB3M of Zone control interface.</li> <li>• The cable is connected to Remote controller.</li> <li>• Address of Remote controller(Main RC) is 101.(This is default setting.)</li> </ul>

#### (2) Optional temperature sensor check

If the optional temperature sensors are connected, please confirm that LED of the interface becomes in following state after confirming communication .

SW500

1	2	3	4	5	6	7	8
ON	OFF	OFF	OFF	OFF	OFF	OFF	OFF
OFF	OFF	OFF	OFF	OFF	OFF	OFF	OFF

DIP SW setting

Item	Display	Content
LED1 (Green)	●	Optional temperature sensor 1 is connected.
	○	Optional temperature sensor 1 isn't connected. Please confirm the followings. <ul style="list-style-type: none"> <li>• The cable is connected to CN201 of Zone control interface.</li> <li>• The cable is connected to optional temperature sensor 1.</li> </ul>
LED2 (Orange)	●	Optional temperature sensor 2 is connected.
	○	Optional temperature sensor 2 isn't connected. Please confirm the followings. <ul style="list-style-type: none"> <li>• The cable is connected to CN202 of Zone control interface.</li> <li>• The cable is connected to Optional temperature sensor 2.</li> </ul>

## 7. Before test run

### 7.2. Installing Record

Please fill in the table

#### (1) Option setting

Option	With or without	Name
Main RC	✓	
Sub RC		
Opt. temp. Sensor1		
Opt. temp. Sensor2		
Common zone *1		—

#### (2) Zone setting

Zone	With or without	Name	Temp. sensor	Outlets *1	Spill zone *2
Zone1	✓				
Zone2					
Zone3					
Zone4					
Zone5					
Zone6					
Zone7					
Zone8					
Common zone		—	—		—

\*1 Record the number of outlets and with/without of common zone by referring to "3-1. System outline".

\*2 Set when the system is without common zone.

When all zones are fully closed, a zone which is set to as spill zone will open automatically.

## 8. Initial setting

This chapter contains information about the settings to be made at the time of installation. Please read the instructions carefully and make the settings accordingly.

### 8.1. Initial Settings

#### (1) Initial startup settings

Before turning on the controller, first make sure that the remote controller, zone control interface, indoor units, and outdoor units have been installed properly according to the instructions detailed in the respective manuals. Turn on the zone control interface and the air conditioner units.

a) Main remote controller

The start up screen will appear of Main RC.

After 5 min. later, Home screen will appear automatically.

b) Sub remote controller

The start up screen will appear of Sub RC.

If sub RC registered by Main RC, HOME screen will appear automatically.

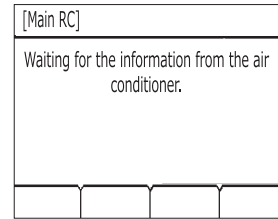

<Fig. 8.1.1>

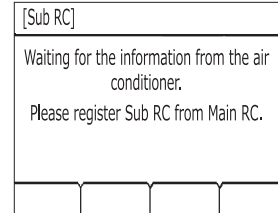

<Fig. 8.1.2>

### 8.2. Service Menu

A password is required to access the Menu (Service) screen or some settings under the Menu (User) screen.

- The initial Service password is "9999." The initial User password is "0000." Change the password as necessary to prevent unauthorized access.
- Make sure the password is available to the maintenance and other necessary personnel.
- The password can be changed to any four-digit number. On the [Login page], enter the old password, touch the [Change] button, and then enter a new password.
- If you forget your password, log in with the master password.  
Master service and user password: 1056

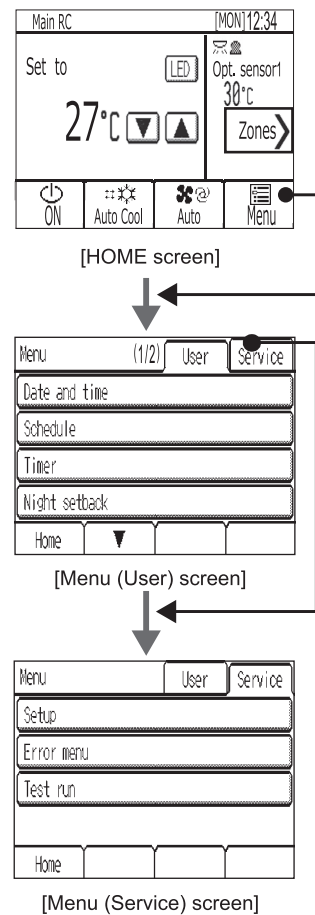



<Fig. 8.2.1>



## 8. Initial setting

### ■Service menu items

Item	Detail	Mandatory	Description	Setting	Default		
(1)	Setup	(a)	Function setting	 *1	Use to make the settings for the indoor units and Zone Control Interface from the controller.	<ul style="list-style-type: none"> <li>Refer to (1) Set menu a) Function setting in page 26</li> <li>Refer to "8.3. Function setting of zone control interface".</li> <li>Refer to the indoor unit installation manual for the detailed explanation of the setting items.</li> </ul>	—
		(b)	Zone setting		Set the following contents: <ul style="list-style-type: none"> <li>Existence of "Sub RC", "Option Sensor1/2", "Common Zone".</li> <li>Existence of "Zone1-8".</li> <li>Sensor applies to each zone.</li> <li>Each zone's outlet number and setting of spill zone.</li> </ul>	<ul style="list-style-type: none"> <li>Refer to (1) Set menu b) Zone setting in page 26</li> </ul>	<ul style="list-style-type: none"> <li>Sub RC Nothing</li> <li>Optional Sensor1: Nothing</li> <li>Optional Sensor2: Nothing</li> <li>Common Zone: Nothing</li> <li>Zone1: Existence</li> <li>Zone2-8: Nothing</li> <li>Sensor of Zone1-8: Indoor Unit</li> <li>Outlet number of Zone1: 1</li> <li>Outlet number of Zone2-8: 0</li> <li>Spill setting of Zone1: Valid</li> <li>Spill setting of Zone2-8: Invalid</li> </ul>
		(c)	Name setting		Set the name of Zone1-8, Main RC, Sub RC, Optional Sensor1/2.	<ul style="list-style-type: none"> <li>Refer to (1) Set menu c) Name setting in page 27</li> </ul>	Main RC = "Main RC" Sub RC = "Sub RC" Optional Sensor 1 = "Opt. sensor1" Optional Sensor 2 = "Opt. sensor2" Zone1 = "Zone1" (Zone2-8 = "Zone2-8")
		(d)	Cool/Heat Display		Use to show or hide the operation mode signs (Cool / Heat) on the HOME screen while the air conditioning units are operated in the Auto mode.	Select between Show / Hide	Auto : show
		(e)	Telephone number		Use to enter the telephone number of the maintenance personnel (max.13 numbers). This number will be displayed on the screen that appears when an error occurs.	Use numerical characters and hyphens.	Blank
		(f)	LED color Adjustment		Adjusts the LED indicator color.*2	Set the R(Red), G(Green), B(Blue) color ratio.	Blue :R, G, B=0, 0, 100 L.Blue : R, G, B=0, 40, 60 Purple : R, G, B=40, 0, 100 Red : R, G, B=100, 0, 0 Pink : R, G, B=80, 20, 40 Orange: R, G, B=100, 40, 0 Yellow : R, G, B=60, 80, 0 Green : R, G, B=0, 100, 0 Lime : R, G, B=40, 100, 0 White : R, G, B=80, 100, 40
		(g)	Reset RC		Use to initialize the memory on the controller. *3	Touch the Reset button.	—
(2)	Error menu	(a)	Self check		Use to check the error history of the desired unit and to reset the error history.	Sets the monitor targets and displays error history. Reset button : Deletes the error history.	—
(3)	Test run				Use to test the air conditioning units. The test-run will automatically end in two hours.	<ul style="list-style-type: none"> <li>Refer to (3) Test run in page 29</li> </ul>	—

\*1 When connecting the zone control interface to PEA-RP·GAA model, set the air conditioning unit as the following table.

Unit	Function number	Function setting
IC (Air conditioning units)	02 (Indoor temperature detecting)	2 (Set by indoor unit's remote controller)

\*2 The LED indicates the operation status of air conditioning units in colors. Refer to "LED Indicator" in the instructions book.

\*3 All settings information will be cleared to the default.

#### [Data backup during power failure]

All the data for items except items (1)-(g) Reset RC, and (3) Test run are nonvolatile, and will be backed up even during power failure.

Data for items (1)-(a), and (2)-(a) will be backed up on the air conditioning unit or zone control interface side.

## 8. Initial setting

### (1) Setup menu

#### a) Function setting

- ① Select "Unit IC (air conditioning units)" (\*1) or "IF (Zone control interface)".  
\*1 The functions may not be available depending on model types.
- ② When you select Function number which you want to confirm and touch [Conf] button, the current setting contents are displayed in [Function setting] field.
  - While monitoring contents for confirm, "Monitoring" is displayed.
  - When the monitoring is completed, "Completed" is displayed.
  - When the error happens, "Request denied" is displayed.
- ③ Select "Function mode number" you want to change the function, and select "[Function setting]".
  - Please refer to indoor unit's manual or "8.3. Function setting of zone control interface" for the details.
- ④ When you touch [Set] button, change is set.
  - While setting contents for change, "Setting" is displayed.
  - When the setting is completed, "Completed" is displayed.
  - When the error happens, "Request denied" is displayed.

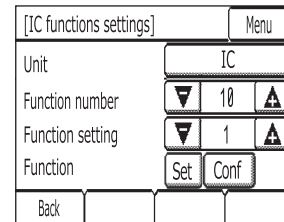

<Fig. 8.2.2>

#### b) Zone setting Mandatory

- ① Set the existence or not of Sub RC, Optional Sensor 1/2, Common zone. (Yes = Existence, No = not connected)  
After that, touch [Next] button.

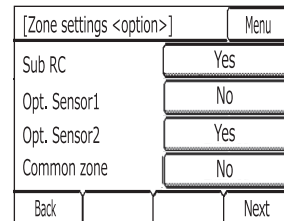

<Fig. 8.2.3>

- ② Set the existence or not of zone1-8.  
After that, touch [Next] button.

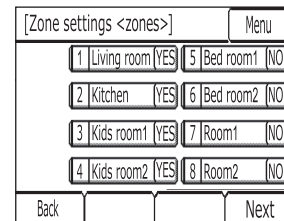

<Fig. 8.2.4>

- ③ Select the zone you want to set in detail by touching [▼][▲] button in [Zone] field.
- ④ Select the sensor to assign to the zone [sensor] field.
- ⑤ Set the number of air outlets by touching [▼][▲] button in [Outlets] field.
- ⑥ Select spill zone setting in [Spill zone] field.
- ⑦ After all setting is done, touch [Done] button.
  - When you select "Common" in [Zone] field, the following screen is displayed.  
Set number of outlet for common zone.

When the zone setting is made, ensure that air blows out from the air outlet in every zone by turning ON the zone one by one.

If the spill zone setting is made, in addition to the above, ensure that air blows out from the air outlet in the spill zone after turning OFF all the zones.

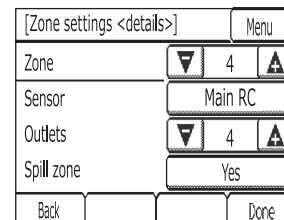

<Fig. 8.2.5>

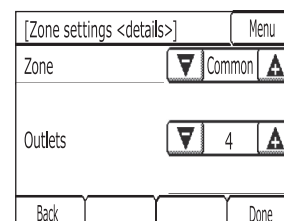

<Fig. 8.2.6>

## 8. Initial setting

### c) Name setting

#### Set Zone name

##### ① Select [Zone name]

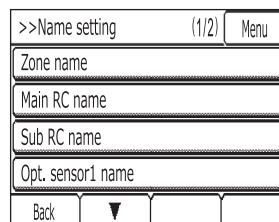

<Fig. 7.2.12>

##### ② Touch [Edit] button of zone you want to change the name .

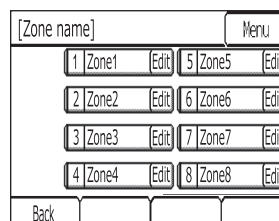

<Fig. 7.2.13>

##### ③ Display [List] screen.

- When you want to select the name from list, please touch the character string of the candidate.

[List] screen has 2 pages. Reshuffling of the page is done by touching [▼][▲].

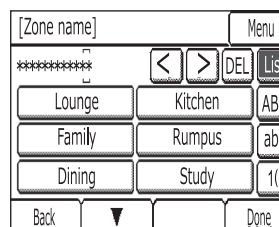

<Fig. 7.2.14>

- When you want to input the upper-case alphabet characters, please touch [ABC] button. The following screen is displayed.

The following screen has 2 pages. Reshuffling of the page is done by touching [▼][▲].

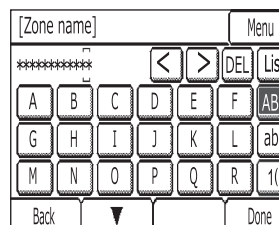

<Fig. 7.2.15>

- When you want to input the lower-case alphabet characters, please touch [abc] button. The following screen is displayed.

The following screen has 2 pages. Reshuffling of the page is done by touching [▼][▲].

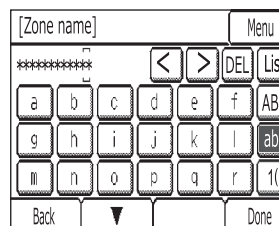

<Fig. 7.2.16>

- When you want to input the number and sign, please touch [1()] button. The following screen is displayed.

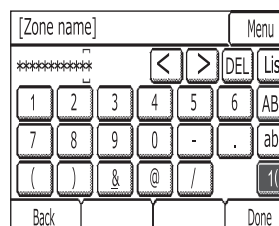

<Fig. 7.2.17>

## 8. Initial setting

d) Cool/Heat display

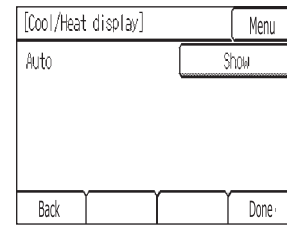

<Fig. 7.2.18>

e) Telephone number

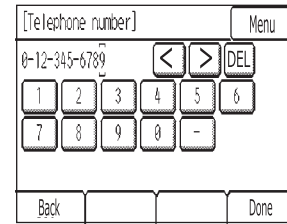

(max. 13 numbers)

<Fig. 7.2.19>

f) LED color adjustment

R (Red), G (Green), B (Blue): "+"...Darken, "-"...Lighten Reset: Restores the default settings for the display color.

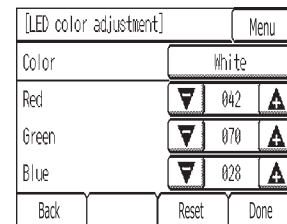

<Fig. 7.2.20>

g) Reset RC

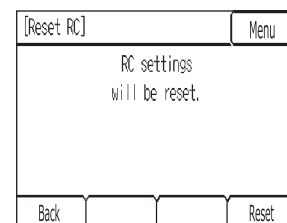

<Fig. 7.2.21>

## 8. Initial setting

### (2) Error Menu

a) Self check

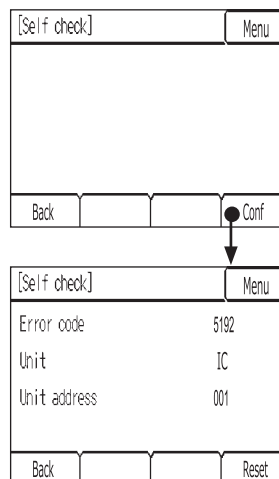

<Fig. 7.2.22>

### (3) Test Run Mandatory

(a) Read the section about Test run in the indoor unit Installation Manual before performing a test run.

If indoor unit does not have the function of test run, remote controller will display the error code (0403) after 1 minute.

(b) During the test run, indoor units will be forced to operate in the Thermo-ON status.

Except the set temperature, normal operation functions are accessible during test run.

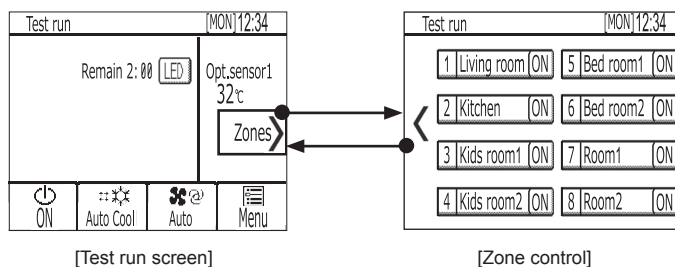

<Fig. 7.2.23>

### 8.3. Function settings of zone control interface

Mode	Settings	Mode No.	Setting No.	Initial setting
Sensor determination method under multiple zones turned ON	Average *1	1	1	○
	Inlet temperature sensor		2	
Fan control	Normal	2	1	○
	Invalid low fan speed		2	
	Invalid low and mid fan speeds		3	

\*1 When the zones turned ON which set the inlet temperature sensor, airconditioning unit controlled by the inlet temperature sensor.

## 9. Troubleshooting

Number	Symptoms	Assumed Causes	Solutions
1	Poor temperature control	If duct static pressure is too high, indoor unit will go into frost prevention mode.	Ensure that ducts have equal pressure loss. Increase the size of the main duct supply air to the problem area to decrease pressure loss.
			Change function setting Mode 2 to value 2, this will disable low fan speed. Refer to "8.2.Service Menu"
			Change indoor unit's static pressure setting to a higher static. Refer to "8.2.Service Menu"
		Sensor has been assigned to the incorrect zone	Check the correct sensor has been assigned to the correct zone.
		Sensor location is poor	Reinstall sensor so it is not in direct sunlight, in direct air flow path, near an electrical machine or influenced by an external heat source. Ensure sensor is sensing the correct area, do not install in cupboard etc.
Outlets on a zone are not balanced	Ensure that equal airflow is achieved from each outlet on a given zone. Install blade dampers to balance airflow to each outlet.		
2	No air flow	Faulty zone motor	Replace zone motor.
		Zone motor incorrectly wired	Check wiring, ensure zone opens and closes correctly.
		Check fuses on zone controller interface	Investigate cause and replace blown fuse.
		For 24V AC model, ensure transformer is connected and supply correct voltage	Check 24V AC transformer
		Ensure indoor unit is turned on, and indoor fan is running.	Check operation of indoor unit and fan motor, also check if unit is not in defrost mode, or pre-warming indoor heat exchanger in heating mode.
3	No display on controllers	Power to indoor unit and zone controller interface is off.	Check power supply to indoor unit and zone control interface.
		Controllers not wired correctly	Check wall controllers are wired to TB3M of zone controller interface board, circuit rating is 24-30V DC.
4	System settings randomly changing	Schedule settings set	Check schedule settings including energy save options and disable.
		Communication cables between indoor, zone controller interface and wall controller effected by electrical noise	Ensure correct segregation of communication cables as per installation manual. If wall controller cables exceed 10m, ensure screened cable 1.25mm <sup>2</sup> or bigger has been used.
5	6600 error on controllers when 2nd controller is installed	Sub controller's address has not been set to 151	Set sub controller's address to 151, refer to installation manual
6	Error codes are different from other Mr. Slim models.	M-net codes are used for this zone controller.	Use the reference table below.

## 10. Supplementary information

Error Code		Symptom
4 disit code	2 disit code	
5101	P1	Intake sensor error
5102	P2	Pipe (Liquid or 2-phase pipe) sensor error
5103	P9	
6840,6843	E6	Indoor/outdoor unit communication error
6842	E7	
5701,2503	P4	Drain sensor error
2502	P5	Drain pump error
2500	PA	Forced compressor error
4114	PB	Fan motor error
1503	P6	Freezing/Overheating safeguard operation
1504		
7130	EE	Communication error between indoor and outdoor units
1110	P8	Pipe temperature error
6831	E4	Remote controller signal receiving error
6834		
0404	Fb	Indoor unit control system error (memory error, etc.)
6201	E1	Remote controller control board error
6202	E2	
6841	E9	Indoor/outdoor unit communication error (Transmitting error) (Outdoor unit)
4210	UP	Compressor overcurrent interruption
5104,5132	U3	Open/short of outdoor unit temperature sensors
5105,5106,5107,5110,5130,5131,5133,5134	U4	
4100,4217,4218	UF	Compressor overcurrent interruption (When compressor locked)
1501,1102,1132	U2	Abnormal high discharging temperature/49C worked/insufficient refrigerant
1302	U1	Abnormal high pressure (63H worked)/Overheating safeguard operation
1504	Ud	
4230	U5	Abnormal temperature of heat sink
4400	U8	Outdoor unit fan safeguard stop
4250	U6	Compressor overcurrent interruption/Abnormal of power module
1502	U7	Abnormality of super heat due to low discharge temperature
4220	U9	Abnormality such as overvoltage or voltage shortage and abnormal synchronous signal to main circuit/Current sensor error
5300	UH	
6600	A0	Address overlap (Remote controller)
6602	A2	Transmission processor hardware error
6603	A3	Transmission line bus busy error
6606	A6	Communication error between device and transmission processors
6607	A7,EF	No ACK error
6608	A8,EF	No response error
5191	EF	Open/short of optional temperature sensor 1
5192	EF	Open/short of optional temperature sensor 2
0403	EF	Communication error between indoor unit and zone control interface
	Others	Other errors (Refer to the technical manual for the outdoor unit.)

## 11. Specifications

Zone control interface	
Weight	PAC-ZC40/80L-E: 2.5kg PAC-ZC40/80H-E: 2.7kg
Allowable ambient temperature	0 to 60°C
Allowable ambient humidity	80% RH or less
External dimensions (W x H x D)	336 x 278x 69mm

Zone remote controller			
Power Source	17–32V DC (for connection to M-NET only)	Receives power from zone control interface via the M-NET transmission cable.	
Operating conditions	Temperature	Operating temperature range	0°C – +40°C (+32°F – +104°F)
		Storage temperature range	-20°C – +60°C (-4°F – +140°F)
	Humidity	20%–90% RH (Non-condensing)	
Weight	0.3kg (11/16 lbs)		
External dimensions (W x H x D)	140 x 120 (123) x 25 (28.8)mm 5-17/32 x 4-3/4 (4-27/32) x 1 (1-5/32) in * The numbers in the parenthesis indicate the dimensions including the protruding parts.		

**Note:**

This equipment has been tested and found to comply with the limits for a Class B digital device, pursuant to Part 15 of the FCC Rules. These limits are designed to provide reasonable protection against harmful interference in a residential installation. This equipment generates, uses and can radiate radio frequency energy and, if not installed and used in accordance with the instructions, may cause harmful interference to radio communications.

However, there is no guarantee that interference will not occur in a particular installation.

If this equipment does cause harmful interference to radio or television reception, which can be determined by turning the equipment off and on, the user is encouraged to try to correct the interference by one or more of the following measures:

- Reorient or relocate the receiving antenna.
- Increase the separation between the equipment and receiver.
- Connect the equipment into an outlet on a circuit different from that to which the receiver is connected.
- Consult the dealer or an experienced radio/TV technician for help.









Installers: Please be sure to put your contact address/telephone number on  
this manual before handing it to the customer.



**mitsubishi electric corporation**

HEAD OFFICE: TOKYO BLDG., 2-7-3, MARUNOUCHI, CHIYODA-KU, TOKYO 100-8310, JAPAN  
Authorized representative in EU: MITSUBISHI ELECTRIC EUROPE B.V.  
HARMAN HOUSE, 1 GEORGE STREET, UXBRIDGE, MIDDLESEX UB8 1QQ, U.K.